



-power in control



ASC SWITCHBOARD DATA SHEET



SOLAR SWITCHBOARD FOR ASC, Automatic Sustainable Controller, PV diesel hybrid

- Integrated solution for PV diesel
- Can be used with or without PMS
- Ideal for retrofit solutions



DEIF A/S · Frisenborgvej 33 · DK-7800 Skive
Tel.: +45 9614 9614 · Fax: +45 9614 9615
info@deif.com · www.deif.com

Document no.: 4921240553A
SW version: 4.57.x or later

1. Application information

1.1. General information.....	3
1.1.1. Main application.....	3
1.1.2. ASC basic functions.....	4
1.1.3. PV power support.....	4
1.1.4. Supported inverters.....	4
1.1.5. Cost-optimised design.....	4
1.1.6. Communication.....	4
1.1.7. Fibre-optic communication.....	5
1.1.8. Battery back-up.....	5
1.2. Inside.....	5
1.2.1. Power supply.....	5
1.2.2. Transducers.....	6
1.2.3. CT connections.....	6
1.2.4. Summation transformer.....	6
1.3. Applications that are supported.....	7
1.4. Diagrams.....	11
1.5. Standard functions.....	12
1.5.1. Standard functions, ASC switchboard.....	12

2. ASC hardware and software options

2.1. Hardware options and slot number location.....	13
2.1.1. Automatic Sustainable Controller.....	13
2.2. ASC configuration.....	16

3. Technical information

3.1. Specifications and dimensions.....	17
3.1.1. Technical specifications, components.....	17
3.1.2. Unit dimensions in mm (inches).....	17

4. Ordering information

4.1. Order specifications and disclaimer.....	18
4.1.1. Other technical switchboard specifications.....	19
4.1.2. Disclaimer.....	19

1. Application information

1.1 General information

1.1.1 Main application

The switchboard is available for applications where the ASC needs to be installed, but there is no practical or adequate space for it or the installation is some distance from the genset park. The switchboard can be installed in power management or in a stand-alone applications. This means stand-alone where the ASC is the only DEIF controller in the system. In a DEIF power management system, the switchboard can also be used in a variant of the shown switchboard.

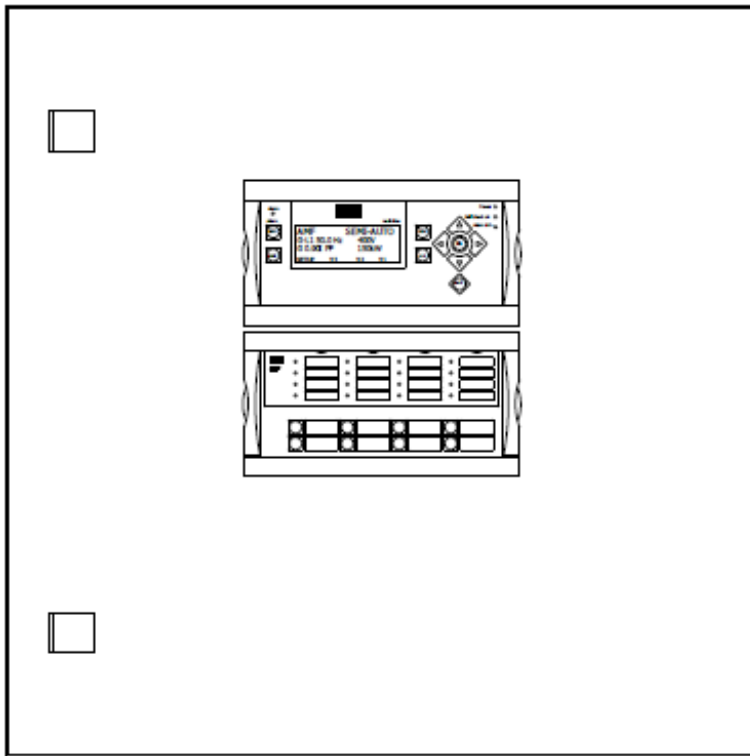

Typically, this switchboard is used where the PV is installed with existing gensets, hence it can be fully equipped with all necessary equipment for supporting this application. This includes measurement transducers, power supply and a summation CT.

1.1.2 ASC basic functions

The switchboard can be used in four variants.

Application	Gensets present	Difference (not present in switchboard)
Off-grid	With gensets	Mains transducer
Grid-tied	Without gensets	Genset transducers Summation transformer
Combined off-grid/grid-tied	With gensets	
Power management (off-grid/grid-tied)	With gensets or without gensets	Mains transducer Genset transducers Summation transformer

It is seen that the largest configuration is a combined, none power management application.

The ASC control system is a system that controls PV penetration when paralleling the PV system with generators or against the utility. The control philosophy is one where the active power and the re-active power is controlled, hereby enabling the inverters to maximise the penetration, either according to the load demand or minimum load of the gensets. The ASC is fully compatible with mains self-consumption requirements with or without sanction load demands as well as fully or partly automated off-grid applications.

The switchboard is applicable where the gensets are placed in a different location than the PV control house. If a genset switchboard offers the space available for the ASC controller, the mentioned switchboard is not always needed.

1.1.3 PV power support

Notice that the ASC is able to control one string of inverter, for example from the manufacturer SMA with their STP 60 string inverter.

A string of inverters may be limited to a certain number of inverters, for example fortytwo (42) STP 60 or ninety-nine (99) FLX Pro. Hence it is noted there is a maximum power that can be controlled from one ASC, for example $[42 \cdot 60 = 2560 \text{ kW}]$ of STP 60.

1.1.4 Supported inverters

Many inverter manufacturers are supported by the ASC. An extensive list is available in the ASC data sheet or by contact to DEIF (support@deif.com).

1.1.5 Cost-optimised design

The design is made with the necessary components for all applications where the ASC is working in stand-alone mode and power management mode. It is already fitted with the necessary components, and all that is needed is commissioning the switchboard with site-specific data.

1.1.6 Communication

A switch is installed for the communication to HMI or SCADA services. The switchboard can be delivered with a ready HMI application (optional) where the status of the gensets and readings of the ASC are implemented.

1.1.7 Fibre-optic communication

In situations where the ASC is communicating with the genset park using DEIF power management, longer distances can be reached using a fibre-optic solution. This is not included in the standard switchboard.

1.1.8 Battery back-up

On request, a battery back-up can be installed in the cabinet. Typically 15 minutes back-up power to allow for switching between sources.

1.2 Inside

Inside the switchboard, the needed components for supporting any combination of grid-tied, off-grid or a combination of the two, are placed.

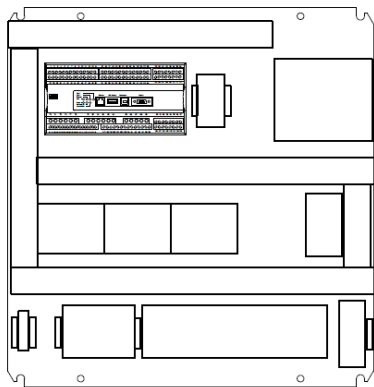

1.2.1 Power supply

The cabinet is intended for 230 V AC supply. Inside the 24 V DC 5 A power supply is powering the transducers, the ASC and the gateway and switch.



1.2.2 Transducers

Three numbers of transducers are preinstalled. The connection 1W3 (or 1W4) is used for balanced load. For unbalanced load, 3W3 (3W4) is used.

- Summated power of the generator(s)
- Summated reactive power of the generator(s)
- Power incoming from the mains feeder



Recommended DEIF transducers:

Type	Output (4-20 mA)	Number of outputs
TAS-331DG	P or Q	1 (two needed per generator)
MTR-3-315	P and/or Q	3 (one needed per generator)

1.2.3 CT connections

Only CT connections with CT links are used in this cabinet. This makes it possible to short and disconnect the components during operation.

1.2.4 Summation transformer

It is possible to use summation transformers to sum up the production of all the gensets in one set of transducers (two TAS-331DG or one MTR-3-315) or a set of transducers can be used per genset.

The summation current transformer is needed when the gensets are not fitted with compatible DEIF controllers or third party controllers, which is typical when this switchboard is used.

If 2-6 gensets are present in the cabinet, the summation transformer is needed. In this way, the TAS for the genset park will be able to measure the park dispatch (gensets only).

The intention is to use the cabinet in the DEIF stand-alone applications. Naturally, it can also be used in the DEIF power management application, but here the transducers and summation CT are not needed. Instead of the summation CT, transducers on each genset can be used.

When ordering the switchboard, it is necessary to explicitly mention the present CT ratio on the gensets.

Genset number	Genset CT primary current	Genset CT secondary current
Example given	1000	5
1		
2		
3		
4		
5		
6		



In applications with unbalanced load, we recommend 3W3. One summation CT is needed per phase.

1.3 Applications that are supported

The applications that are mentioned here are the none power management applications, this means applications where the gensets are not controlled by AGC in combination with the ASC.

Detailed description of the applications can be found in the designers reference handbook for the ASC.

Off-grid

The off-grid application is described with this two-generator example (cabinet not shown for simplifying reasons). It is seen that the P and Q dispatched from the gensets are measured and signaled to the ASC. Based on this information, the ASC is able to regulate the PV precisely to make sure that the load of the gensets are as low as possible compared to the requirements from the engine builder.

Example with one set of transducers per generator (TAS-331DG) instead of summation CTs:

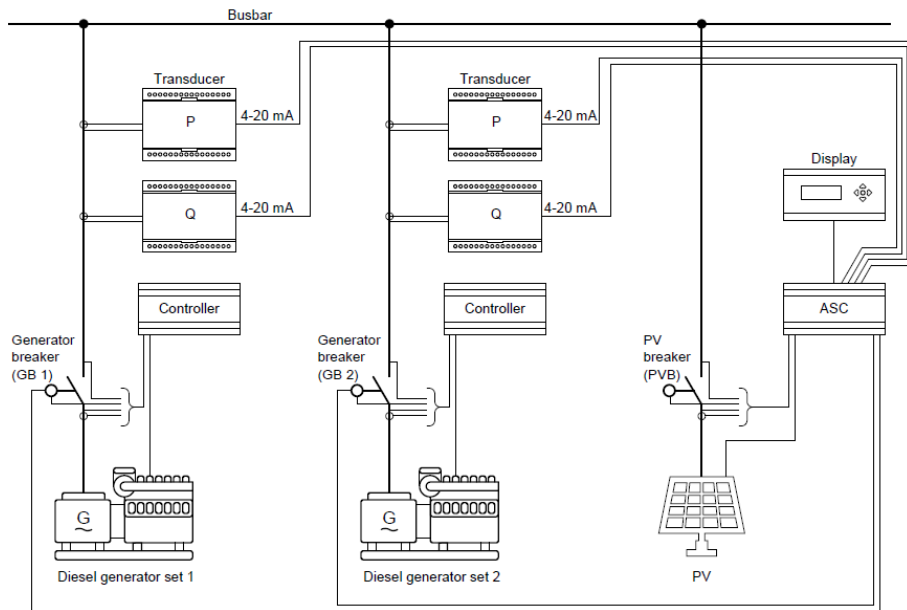

Grid-tied

In the grid-tied application, the PV penetration is regulated by the ASC whenever the mains feeder breaker is closed. The set point of the PV is adjusted according to dispatch requirements in all available modes (when MB is closed: peak shaving, mains power export, fixed power) offered by DEIF automated applications.

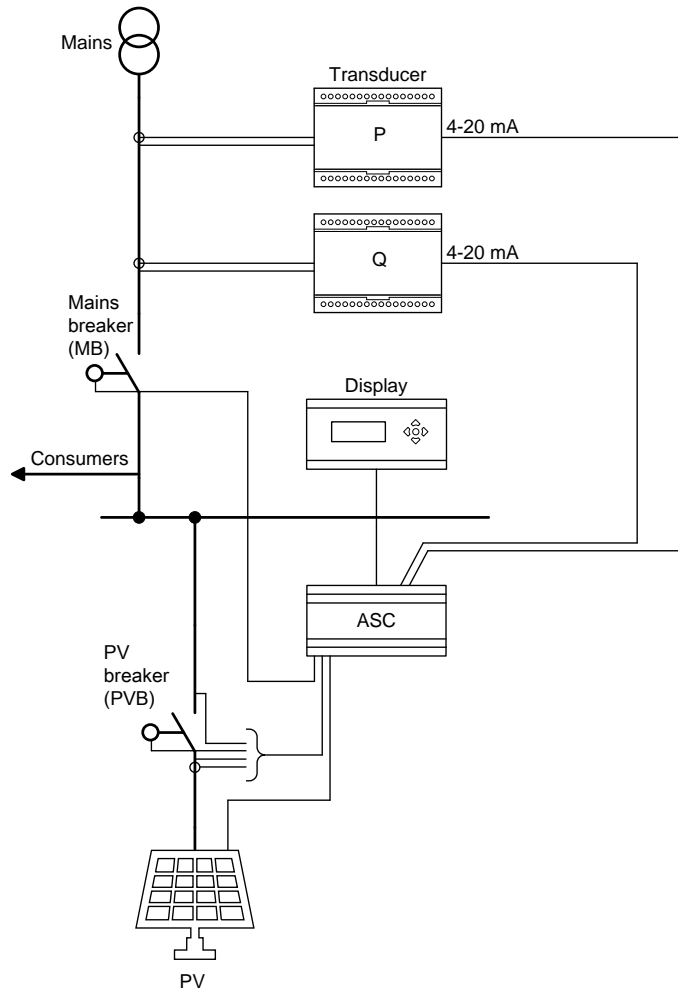

Combination

In the combination mode (combination between off-grid and grid-tied), all available modes are possible, that is island mode as well as parallel to mains modes (peak shaving, mains power export, fixed power). The set point is reached by adjusting the PV penetration according to the genset load requirements and the mains dispatch requirements.

Example with one set of transducers per generator (TAS-331DG) instead of summation CTs:

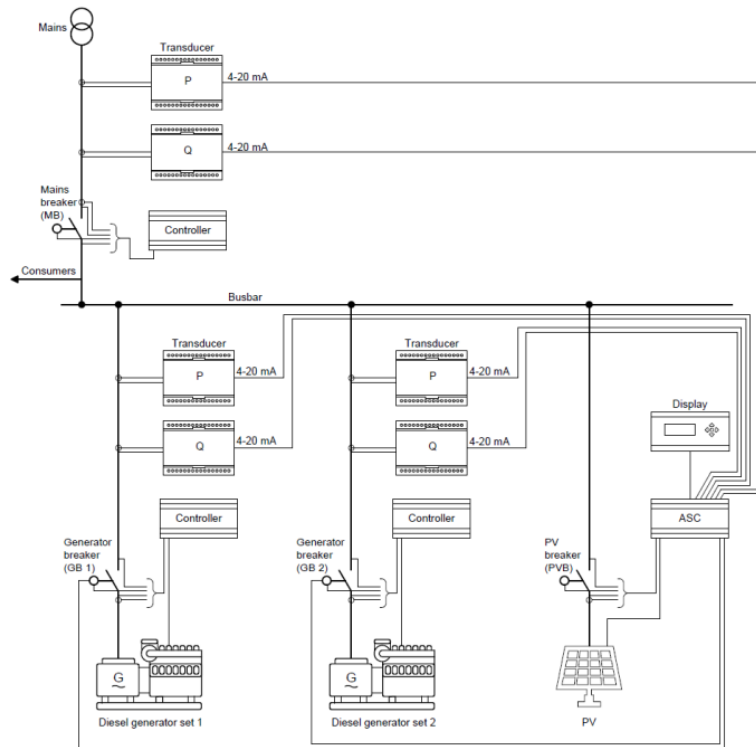

1.4 Diagrams

The switchboard diagrams will be delivered as pdf diagrams or in electronic form.
If it is favourable to build the switchboard locally, it is possible to order the diagrams separately.

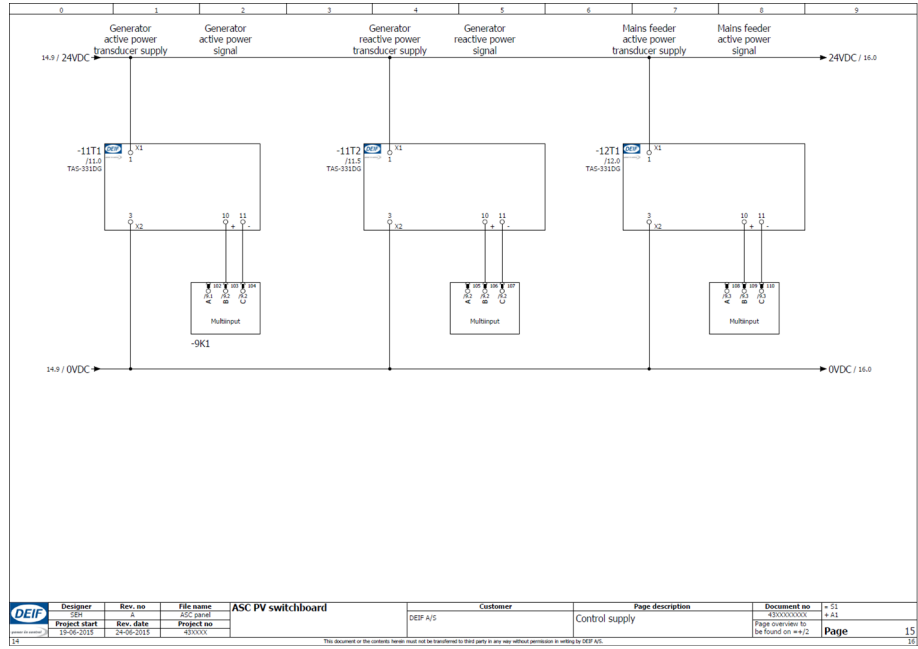

DEIF can assist with arranging the switchboard as a package when required.

1.5 Standard functions

1.5.1 Standard functions, ASC switchboard

Function	included
Measuring	
1W3 (balanced load only)	X
1W4 (balanced load only)	X
2W3	X
3W4	X
Applications	
Island operation	X
Fixed power/base load	X
Peak shaving	X
Mains power export	X
(Power management 0-32 incoming feeder and 0 to 32 gensets) (Max number of gensets and mains incomers = 32)	
Island operation	X
Fixed power/base load	X
Peak shaving	X
Load take over	X
Mains power export	X
DEIF transducer mains feeder, 1 unit (kW)	X
DEIF transducer DG(s) active power, 1 unit (kW)	X
DEIF transducer DG(s) reactive power, 1 unit (kvar)	X
Ethernet switch, 8 ports unmanaged	X
Modbus master gateway for inverter control, RS-485 to Ethernet, 1 pce	X
DCP, 230 V AC/24 V DC power supply (5 A)	X
Summation current transformer	X

The power management application is of course also supported, but the switchboard needs fewer components, which means no summation CT and no transducers.

In a power management system, the maximum number of gensets and mains present in the system is 32. If for example 3 mains feeders are present, the number of gensets that can be installed is 32-3=29.

Transducers and summation current transformers need to be specified with the order.

2. ASC hardware and software options

2.1 Hardware options and slot number location

2.1.1 Automatic Sustainable Controller

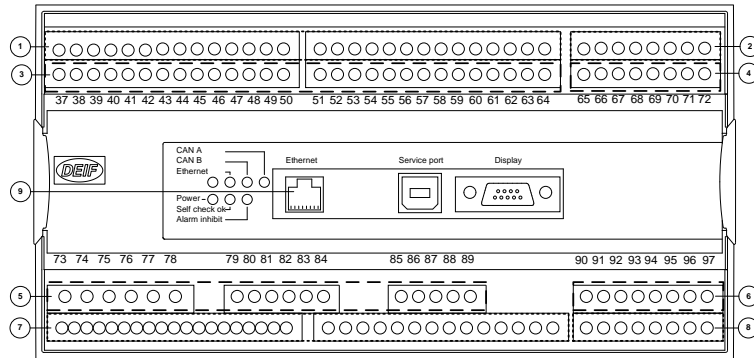



The numbers in the drawing above refer to the slot numbers indicated in the below table.

The ASC can be altered according to needs. The I/O count of the switchboard must be changed if the option configuration changes, please contact DEIF for details.

Slot #	Option/standard	Description	Prewired
1		Terminal 1-28, power supply	
	Standard	8 to 36 V DC supply, 11 W; 1 × status output relay; 5 × relay outputs; 2 × pulse outputs (kWh, kvarh or configurable open collector outputs); 5 × digital inputs	Power supply PVB open/close MB/PVB feedback
2		Terminal 29-36, communication, inputs/outputs	
	H2	Modbus RTU (RS-485)	Data A/B
3		Terminal 37-64, inputs/outputs/load sharing	
	Standard (ASC PM) Option M12 (ASC-4)	13 × digital inputs; 4 × relay outputs	DG 1-6 GB on 2 relay outputs (ASC PM only)
4		Terminal 65-72, inputs/outputs	
	E2	2 × 0(4) to 20 mA outputs	1 4-20 mA out
	M13.4	7 × binary inputs	
	M14.4	4 × relay outputs	
5		Terminal 73-89, AC measuring	
	Standard	3 × busbar voltage; 3 × busbar current; 3 × mains voltage	All
6		Terminal 90-97, inputs/outputs	
	F1	2 × 0(4) to 20 mA outputs, transducer	
	M13.6	7 × digital inputs	
	M14.6	4 × relay outputs	
	M16.6	4 × multi-inputs (4 to 20 mA or 0 to 5 V or Pt100)	

Slot #	Option/standard	Description	Prewired
7		Terminal 98-125, PV I/F	
	Standard	8 to 36 V DC supply; 3 × multi-inputs; 7 × digital inputs; 4 × relay outputs power management communication, CAN port A and B	power supply 3 transducer inputs Can bus A and B
8		Terminal 126-133, in-puts/outputs	
	M13.8	7 × digital inputs	
	M14.8	4 × relay outputs	
	M15.8	4 × 4...20 mA inputs	2 config inputs
9		LED I/F	
	Standard	- Modbus TCP/IP	To switch
Standard accessories			
		AOP-1	
		DU-2	

 There can only be one hardware option in each slot. For example, it is not possible to select option H2 and option M13.2 at the same time, because both options require a PCB in slot #2.

 Besides the hardware options shown on this page, it is possible to select the software options mentioned in the chapter "Available software options" in the data sheet of the ASC type in question.

2.2 ASC configuration

This shows the configuration unless otherwise changed when ordering. Terminals with text are prewired, but all can be used.

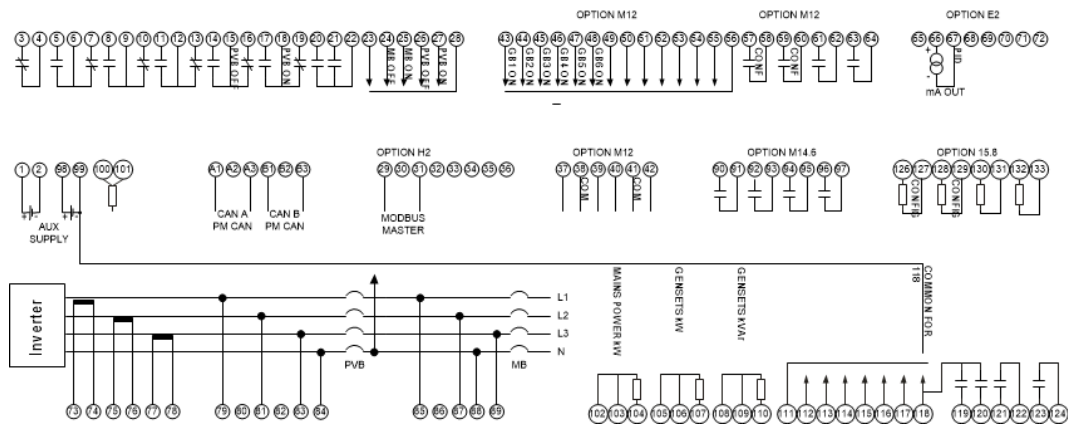

3. Technical information

3.1 Specifications and dimensions

3.1.1 Technical specifications, components

Full specifications can be seen on www.deif.com for ASC, DCP, KSU, MTR, SUSK, TAS.

3.1.2 Unit dimensions in mm (inches)

The dimensions are 600 x 600 x 350 mm (23.62 x 23.62 x 13.78).

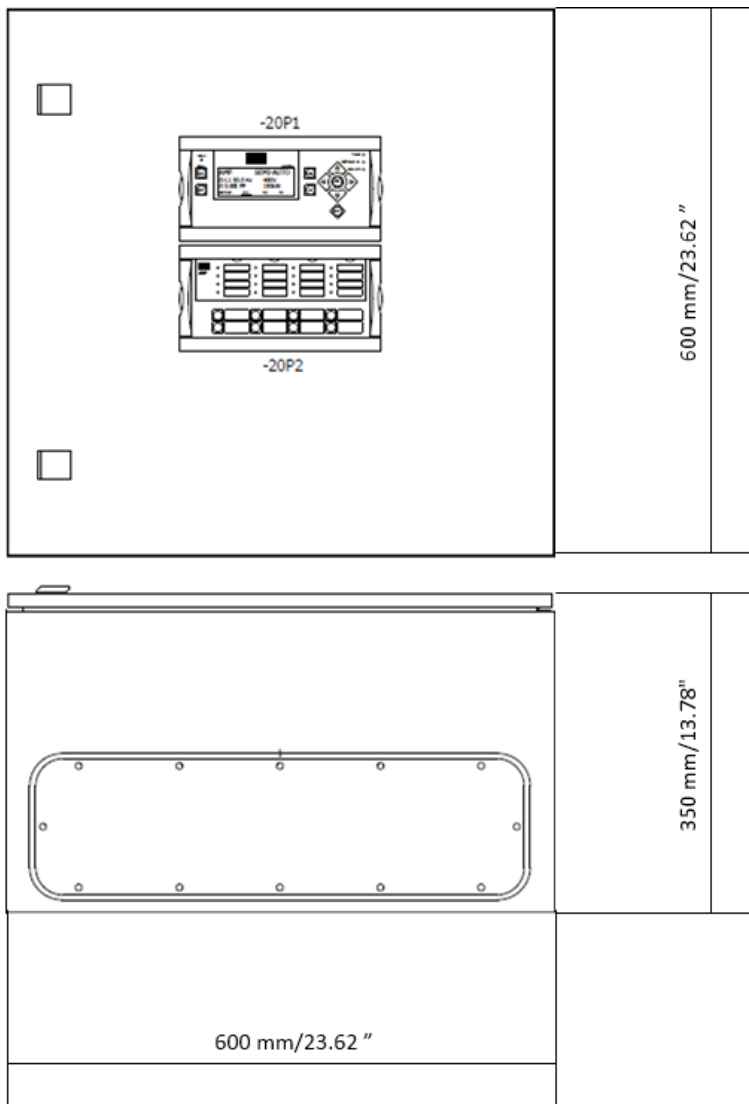

4. Ordering information

4.1 Order specifications and disclaimer

Contact DEIF for ordering information.

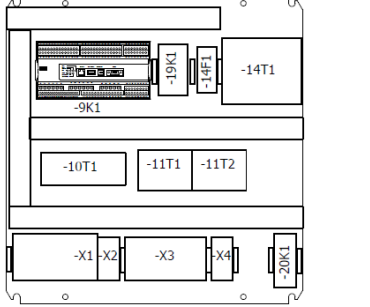
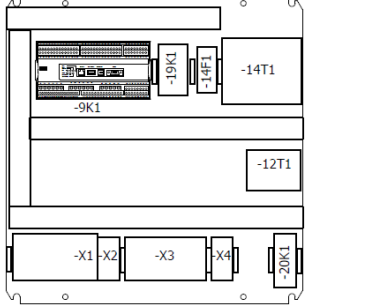
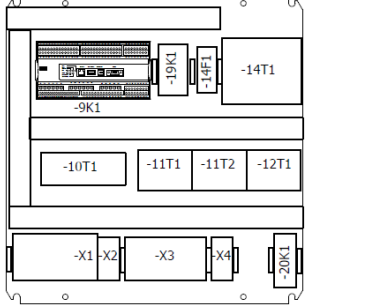
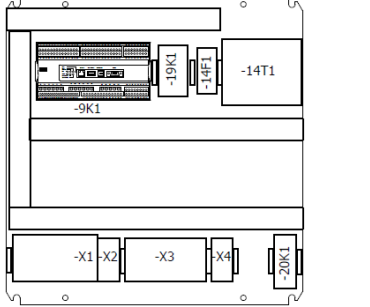
Application	Gensets present	Difference (not present in switchboard)
Off-grid	With gensets	
Grid-tied	Without gensets	
Combined off-grid/grid-tied	With gensets	
Power management	With gensets or without gensets	

Options	Comment	Difference
ASC with various options		
MTR-3-315	Instead of TAS-331DG	Provides RS-485 Modbus interface

Number of gensets	Comment	CT ratio
Genset 1-16	Not necessary for power management applications	List each CT ratio

TAS-331DG	Comment	Coupling
Mains feeder	Order according to TAS-331DG data sheet	3W3 or 3W4
Gensets	Measurement voltage	3W3 or 3W4

4.1.1 Other technical switchboard specifications

Detail	Facts	Comments
Weight	37 kg	
Dimension	600*600*350 mm	
Temperature range, means 24 hour	0-40 deg C	
IP class	IP 52 (54)	Decided by ASC display
Power supply	230 V AC	

4.1.2 Disclaimer

DEIF A/S reserves the right to change any of the contents of this document without prior notice.

The English version of this document always contains the most recent and up-to-date information about the product. DEIF does not take responsibility for the accuracy of translations, and translations might not be updated at the same time as the English document. If there is a discrepancy, the English version prevails.