



CONTENTS:

25.0 INSTALLATION INSTRUCTION 2

25.1 SYSTEM INSTALLATION 2

 25.1.1 Before installing the DELOMATIC system..... 2

 25.1.2 Installing the DGU..... 3

 25.1.3 Installing the CP..... 4

 25.1.4 Connecting the power supply 6

 25.1.5 Installing the ARC-network 6

25.2 HOW TO WIRE 8

 25.2.1 The control panel (CP-1) 8

 25.2.2 The PSM-1 module 10

 25.2.3 The CM-1 module 10

 25.2.4 The IPM-1 module 10

 25.2.5 The OPM-1 module..... 10

 25.2.6 The SCM-1 module..... 11

 25.2.7 The SCM-2 module..... 14

 25.2.8 The CRM-1 module for short circuit protection 16

 25.2.9 The CRM-1 module for differential current protection 17



25.0 INSTALLATION INSTRUCTION

The installation instruction contains both general and specific information on how to carry out the installation of the DELOMATIC system. By observing the advice given in this installation instruction, a safe and correct installation of the DELOMATIC system is ensured.

The installation instruction consists of three main parts:

- a *system installation* which contains general precautions which should be observed during installation
- information on *how to wire* the individual hardware modules
- complete *wiring tables* for the DGU's and CP('s)

25.1 SYSTEM INSTALLATION

The system installation consists of the following five main parts:

- pre-installation considerations regarding the DELOMATIC system.
- installation of the DGU in the cabinet.
- installation of the CP in the cabinet.
- connecting power supply to the DGU and the CP.
- establishing the ARC-network communication link.

25.1.1 Before installing the DELOMATIC system

Before installing the DELOMATIC system, a number of very important precautions and restrictions must be observed.

Precautions regarding the ambient temperature of the DELOMATIC system

The ambient temperature (T_{AMB}) has a decisive influence on the expected lifetime for the electronic circuits in the DGU and the CP.

AMBIENT TEMPERATURE			EXPECTED LIFETIME
T_{AMB}	\leq	40 °C	10 years
T_{AMB}	\leq	50 °C	5 years
T_{AMB}	\leq	60 °C	30 months
T_{AMB}	\leq	70 °C	15 months

NOTE! *It is highly recommended to install the DGU and CP at a cool location in the cabinet in order to achieve the longest lifetime for the DELOMATIC system.*

Speed governor interface

For both mechanical and electronic speed governors it is a demand that the governor is equipped with a speed droop mode in which the governor always should be when connected to the DELOMATIC system.

Max. wire/cord dimensions

The screw terminals at all of the DELOMATIC modules may not be connected to more than max. 2.5 mm² single or multi-stranded wires/cords, unless other specifications are stated.

Input channels

Only potential free contacts may be used as *binary* input signals to any binary input channel in the DELOMATIC system (notice this applies for *all* DELOMATIC modules).

25.1.2 Installing the DGU

The below text contains information necessary in order to carry out the installation of the DGU. The DGU rack is produced in two different sizes; a 84 TE and a 60 TE rack (the "A" measure on the following figure).



84TE:	A = 426.7 mm	B = 465.1 mm	C = 483.0 mm
60TE:	A = 304.8 mm	B = 343.2 mm	C = 361.1 mm

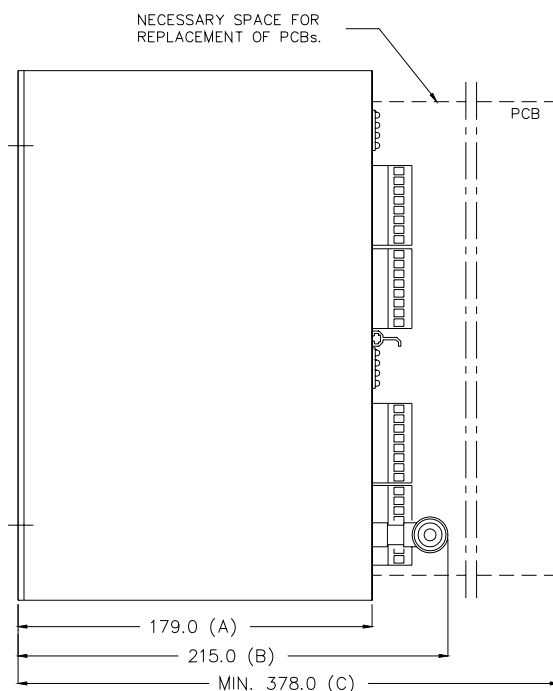

Observance of the below mentioned practical precautions during installation of the rack, are necessary in order to avoid problems regarding free space in front of the rack.

During operation, the ARC-network connector must be clear of the front door of the cabinet. *Otherwise the ARC-network may not be able to operate.* The distance from the back of the cabinet to the inside of the closed cabinet door must thus be larger than the specified "B" measure in the illustration to the left.

The distance from the back of the cabinet to any fixed objects in front of the rack (with an open cabinet door) may furthermore be minimum the specified "C" measure in the illustration to the left. *This is necessary in order to ensure sufficient working space for replacing and inspection of the DELOMATIC hardware modules.*

Grounding the DGU

When mounting the DGU, it is very important to make sure the metal rack frame gets a solid electrical connection with the presumed grounded cabinet. A firmly grounded DGU is important both due to crew/operator safety precautions, but also in order to form a complete grounded metal cage, which is part of the approved EMC.

Ensuring the DELOMATIC systems electromagnetic compability (EMC)

The DELOMATIC system is CE marked. In short this means the DELOMATIC systems electrical noise immission and emission has been examined and found to apply with the EN for electromagnetic compability (EMC).

A DGU correctly configured with hardware modules and cover plates, thus forming a complete grounded metal cage, is an important part of the approved EMC. In order to ensure an intact EMC, the rack frame and the metal front covers must be in a solid electrical connection.

NOTE! *It is thus highly recommended to make sure that all hardware modules are firmly mounted in the rack frame after completing the installation of the DGU. This is done simply by tightening all the screws in the front covers.*

25.1.3 Installing the CP

Before installing the CP it is important to identify which CP('s) corresponds to DGU number 1 and which CP('s) corresponds to DGU number 2 etc.

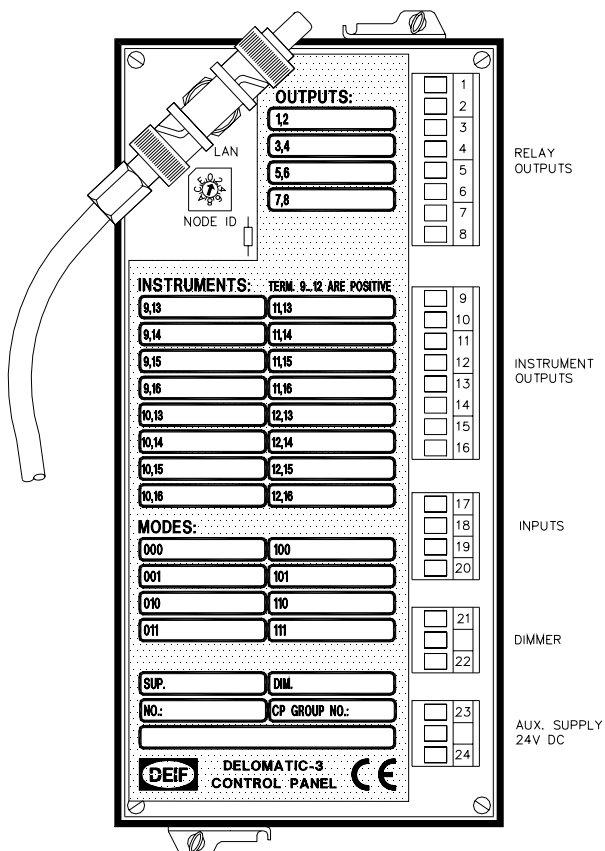

This is necessary, because the transmitted alarm messages are dedicated to a certain DGU and are as such *only* displayed at the corresponding CP('s).

Furthermore the CP('s) corresponding to DGU no.1 have a number of additional instrument outputs which are not present at CP's corresponding to any of the other DGU's.

The position of the ARC-network node ID switch decides which DGU the CP corresponds to.

If the ARC-network node ID switch on the CP is set to 1 the CP will correspond to DGU number 1 etc.

The ARC-network node ID. switch at the CP are delivered factory set. The corresponding DGU number is furthermore identified at the label at the back of the CP.

The ARC-network is connected to BNC connector in the left top corner of the CP as described in paragraph 15.1.5.

The below illustrations states the necessary measures in order to carry out a correct installation of the CP in the cabinet.

The drawing to the right in the below illustration specifies the measures for cutting the holes in the cabinet where the CP is to be placed.

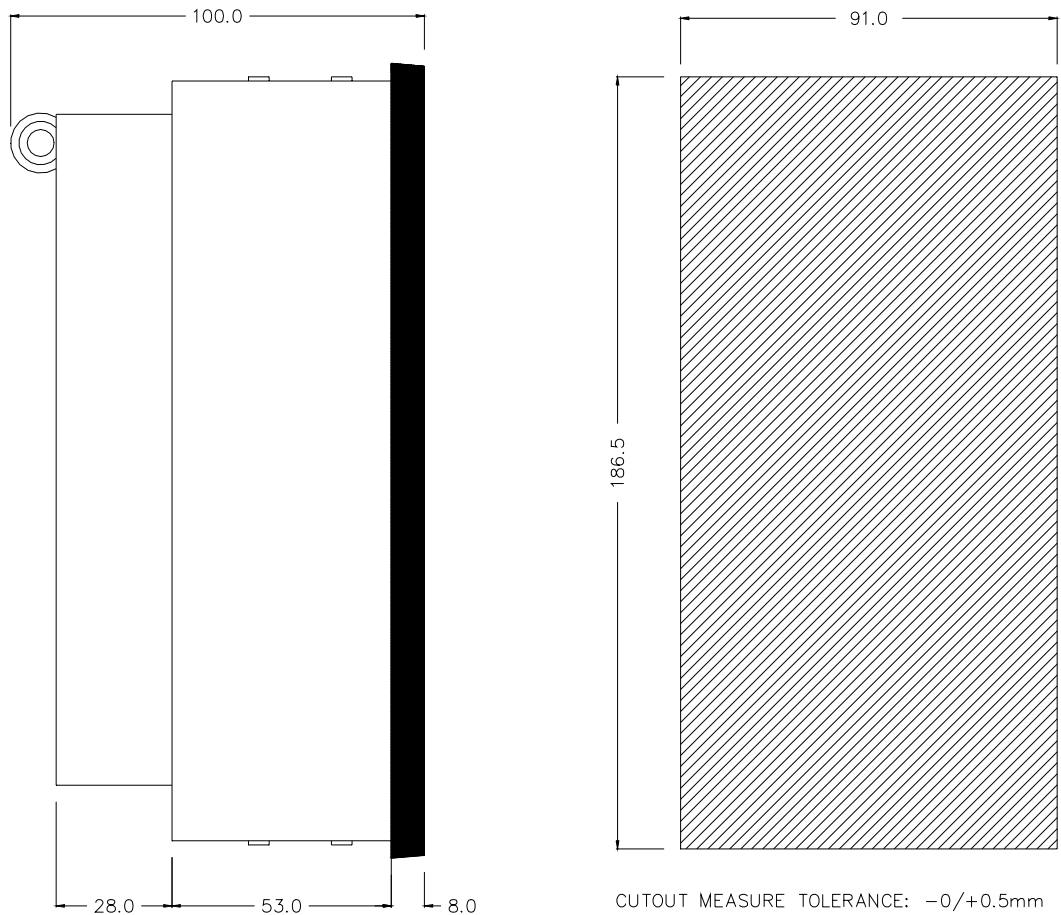

During operation, the ARC-network connector must be clear of any solid objects inside the cabinet. Otherwise the ARC-network may be unable to carry out correct operation.

This means, the distance from the front of the CP's to any solid objects inside the cabinet, must be larger than the measure specified in the drawing to the left in the above illustration.

25.1.4 Connecting the power supply

The DELOMATIC system requires 24 VDC (+25% / -30% incl. ripple voltage) at all supply terminals.

Please refer to the DELOMATIC data sheets where the power consumption of each DELOMATIC module is stated. Based on this information it is possible to calculate the total power consumption of each DGU.

Each CP have a separate power supply terminal.

Each DGU has two different power supply terminals:

- the power supply terminal at the PSM-1 module (switch mode power supply module)
- and
- power supply terminal at the SCM-1 module; *terminals no. 27 - 28*
(for speed governor control in SWBD control)

An additional power supply terminal is present, when the function for internal short circuit protection (carried out by the CRM-1 module) is implemented in the DELOMATIC system:

- power supply terminal at the CRM-1 module; *terminals no. 13 - 14*

NOTE! *All of the above mentioned power supply terminals must be connected to the supply voltage in order for the DGU to be able to carry out automatic operation.*

Even though all power supply terminals always *must* be supplied with a suitable power supply to be able to carry out automatic operation, the speed governor control in SWBD control via the SCM-1 module only require supply to the SCM-1 module to operate (thus there are no automatic functions available). The same goes for the CRM-1 module, in order to obtain a short circuit protection only the supply to the CRM-1 module is required (module operate according to DIP switch setting on the board and must be operated via the terminals on the front).

25.1.5 Installing the ARC-network

The function of the ARC-network is to handle the internal communication between the DGU and the corresponding CP('s) and for exchange and information between the DGU's.

The ARC-network is connected to the BNC connectors, which are present at the CM-1 modules and the CP's in the DELOMATIC system.

The ARC-network is a Local Area Network (LAN) of token ring type, which communication line consists of number of coaxial cables connected in a serial line. The coaxial cables are delivered mounted with BNC straight plugs (3). Numbers in parent refer to the below figures.

The optimal installation of the ARC-network coaxial cables is to locate the communication line separated from other wires. But if this is not possible, then to locate the ARC-network as far away from any power or high voltage wires as possible.

NOTE! *It is highly recommended to install the ARC-network coaxial cables away from high voltage wires e.g. the busbar cables.*

The maximum length of the network is 300 m without repeaters. The length of the coaxial cables between each BNC connector, e.g. between a CM-1 and a CP must as minimum be 1.8 m (the standard DEIF delivered cable length is 2 m.).

All connections of the CM-1 modules, CP's or other types of equipment to the network, are to be made through a BNC T-plug connector (2). Each end-point of the ARC-network is to be terminated with a BNC end-point terminator (4).

The network is furthermore to be supplied with noise reducing ferrite cores (6) which are located *approx. 0.1 m before and after each BNC T-plug connector.*

As maximum 8 DGU's (CM-1's) and 24 control panels (3 pcs. per DGU) may be connected into the same DELOMATIC system (ARC-network). Furthermore communication links for other systems, e.g. alarm systems or graphical user interface systems, may be connected in the ARC-network.

The end-point connection at the ARC-network

The T-plug connection at the ARC-network

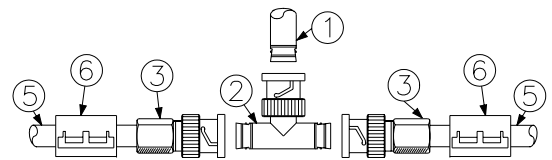
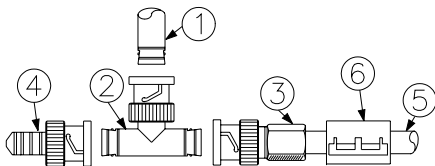

1. BNC connector on the CM-1 modules, CP's or other equipment
2. BNC T-plug connector for two jacks
3. BNC connector straight plug mounted on the coaxial cable
4. BNC connector end-point terminator 93 ohm
5. Coaxial cable
6. Ferrite core

The network must be installed as an open loop string with two end-points. *Parallel lines are not allowed!*

The following three examples show how to make a valid and operational installation of the ARC-network:

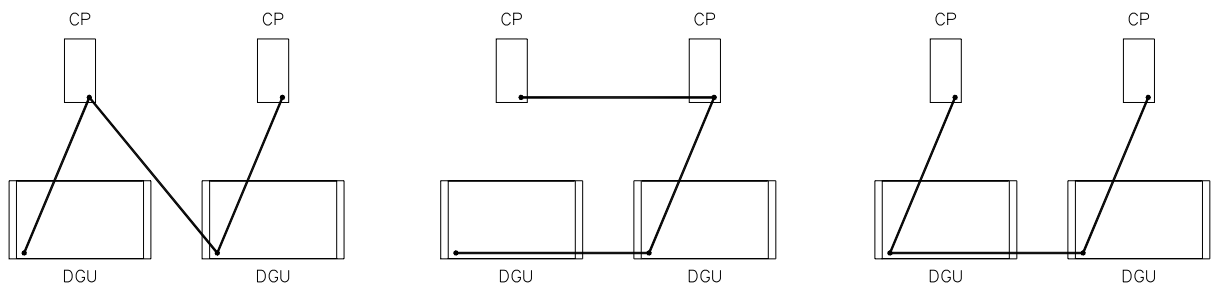

The following two examples show how the installation of the ARC-network may **not** be carried out:

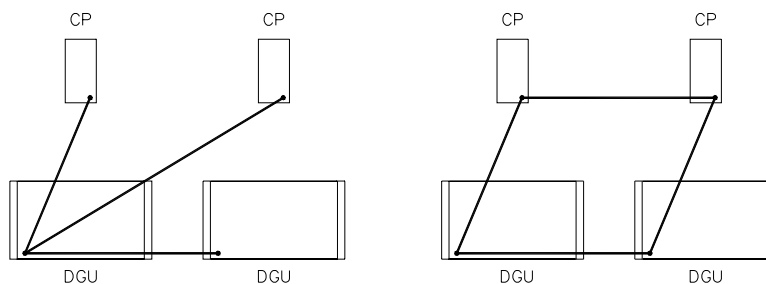

The above two examples *are not able to operate* due to parallel communication lines. Furthermore, the example to the left have *three* end-points, and the example to the right have *none* end-points at all.

NOTE! *As a test of a correct installation of the ARC-network communication line, simply count the number of end-points in the string. If there are more or less than two end-points, the installation of the ARC-network is not valid.*

25.2 HOW TO WIRE

This paragraph contains text and illustrations which provides information on *how to wire* the CP and the DELOMATIC modules, meaning; which type of signals are expected etc.

25.2.1 The control panel (CP-1)

Wiring diagram for the CP control interface

The CP's control interface has:

- 4 relay outputs
- 3 binary inputs
- 1 dimmer input
- 1 power supply terminal

The CP outputs

All relay outputs are potential free outputs with the following contact ratings:

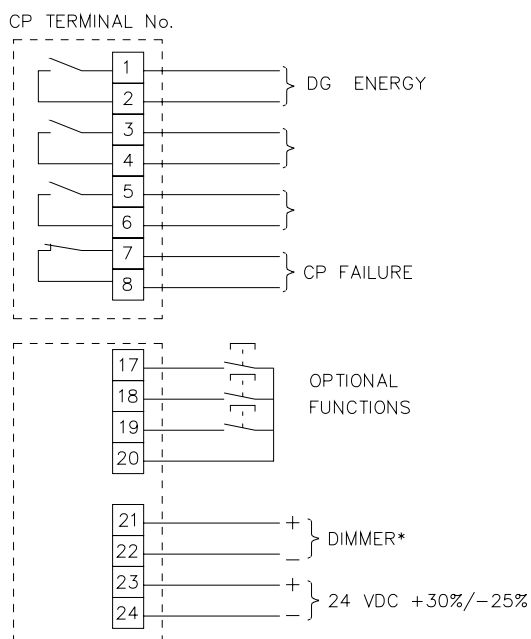

The CP control interface.

Max. AC: 250 V - 5 A - 1000 VA
DC: 250 V - 1 A - 50 W

The binary inputs

The binary inputs may only be connected to potential free contacts.

The dimmer input

The dimmer input is used for control of the background light in CP display according to the below specifications:

illumination:	Input voltage:
max.	open connection
max.	0 VDC ... 8 VDC
no light	8 VDC
linearly increasing	8 VDC ... 24 VDC
max.	24 VDC

NOTE! The dimmer input is a high impedance input (Z_{IN} approx. 21 k Ω).

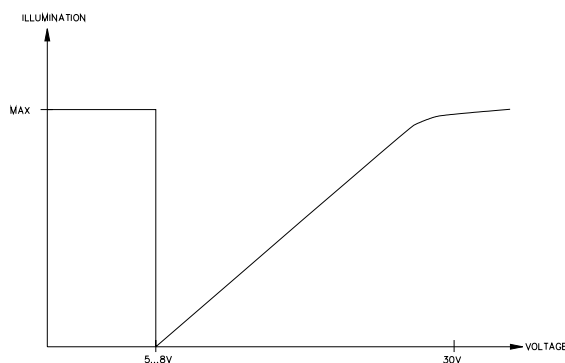

On the figure the voltage is the input voltage on terminals 21-22 on the CP and it shows the illumination in the display on the CP as a function of the input voltage.

Below approx. 5...8VDC the illumination is maximum, but when the voltage becomes higher the illumination is cut to a minimum and then raising with raising voltage until maximum is achieved again at approx. 30VDC.

Wiring diagram for the CP's instrument outputs

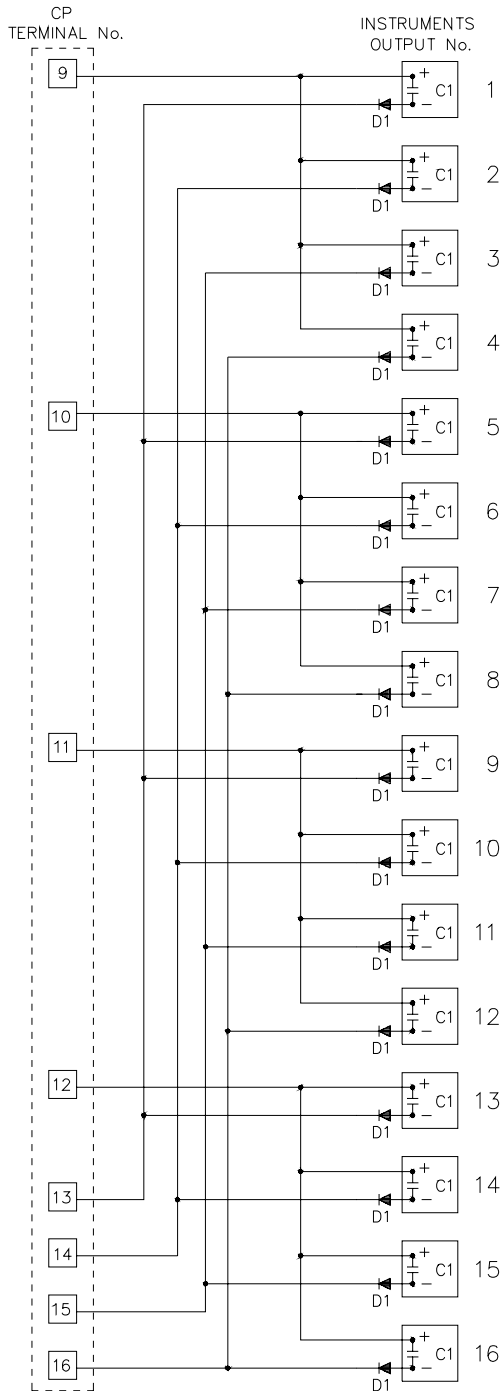

The instrument outputs at the CP are multiplexed pulse width modulated 0...1 mA analogue outputs.

The max. load on the instrument outputs are 1kΩ.

The instruments

Only instruments, which are able to handle this type of signals, may be used in connection with the CP instrument outputs.

DEIF type GQ..X instruments are specially designed for this type of signals. The below mentioned capacitors and diodes are delivered built in the DEIF GQ..X instruments:

Capacitors (C1): Tantalum 100 μF, 3V

Diodes (D1): 1N4148

Designated read-out units

Each instrument output is designated with a specific unit and scale of the read-out value.

Scale of the instrument outputs

NOTE! Please refer to the wiring tables for information regarding the scale of a specific instrument output.

Max. wiring length

The length of the wires between the instrument outputs and corresponding instruments may not be longer than 3 m.

The outputs are scaled according to the actual setup, please refer to paragraph 4.3 System Setup for factory setup.

25.2.2 The PSM-1 module

If the power supply for the DELOMATIC is unstable or under-dimensioned it is recommended to mount a capacitor of min. 1000 μ F (min. 30 VDC) across the power supply terminals at the PSM-1 module to avoid unintended warm restart of the DELOMATIC.

25.2.3 The CM-1 module

Only the ARC-network is to be connected to the CM-1 module. The mounting of the ARC-network is carried out as described in paragraph 15.1.4.

25.2.4 The IPM-1 module

The IPM-1 has 16 input channels which all may be configured individually as either:

- binary input
- analogue current input
- analogue voltage input

Please refer to the wiring list for specific information of the configuration of each channel.

Binary inputs

Only potential free contacts may be used as *binary* input signals.

Cable supervision

Cable supervision is available as an optional function for the binary input channels.

Cable supervision requires that a shunt resistor (3.3 $k\Omega \pm 10\%$) is mounted across the signal transmitting device.

Notice that cable supervision is implemented as default on all analogue inputs which operate with 20% offset (4...20mA / 2... 10VDC).

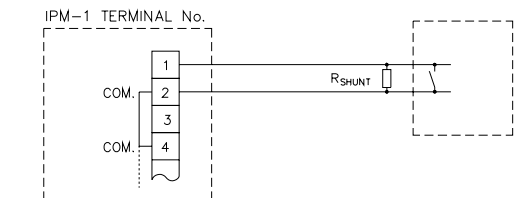

Principle wiring of cable supervision at binary input.

All the "COM. n" terminals are electrical connected to the same potential internally in the IPM-1 modules (this applies for both analogue and binary input channels).

25.2.5 The OPM-1 module

The OPM-1 has 16 output channels which all are relay outputs with the following contact ratings:

Max. AC: 250 V - 5 A - 1000 VA
DC: 250 V - 1 A - 50 W

NOTE! *If the relay outputs are used for control of e.g. relay coils or similarly strong inductive loads it is recommended to apply a noise reducing component (e.g. a capacitor or a free-wheel diode) across the loads.*

25.2.6 The SCM-1 module

The SCM-1 module consists of:

- the multi-transducer unit; *terminals 1 ... 14 located to the left at the SCM-1 front cover*
- the GB ON/OFF unit; *terminals 15 ... 21 located in the middle at SCM-1 front cover*
- the synchronizing unit; *terminals 22 ... 40 located to the right at the SCM-1 front cover*

Wiring diagram for multi-transducer (AC measuring inputs).

The multi-transducer unit has three measuring input groups:

- a three phase generator current measuring input
- a three phase generator voltage measuring input
- a three phase busbar voltage measuring input

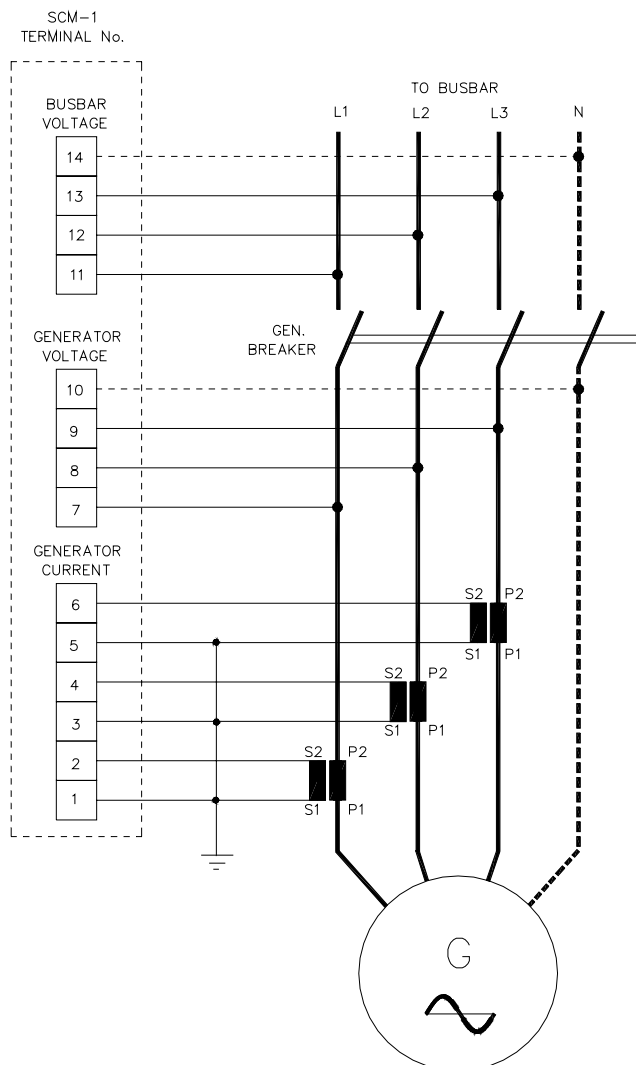

The voltage measuring inputs (both busbar and generator voltage inputs) are able to measure max. 660 VAC.

If measurement of voltages higher than this is required, voltage transformers must be applied.

The shown wiring is a connection to a 3-wire grid with a neutral conductor (dotted lines).

If the SCM-1 is supposed to measure at a 3-wire grid *without neutral conductor*, terminals 10 and 14 are left as open connections (*grounding of the unused "N" terminals may not be done*).

Notice that the screw terminals at the current measuring inputs must not be connected to more than max. 4 mm² single or multi-stranded wires/cords.

WARNING!

Short circuit the current measuring inputs before disconnecting the terminals.

The SCM-1 module has internal current measuring transformers.

Principle wiring of the multi-transducer signals

Wiring diagram for the generator breaker ON/OFF control signals

The generator breaker ON/OFF control signals consists of:

- two binary inputs for GB position feedback signals
- two relay outputs for GB ON/OFF commands

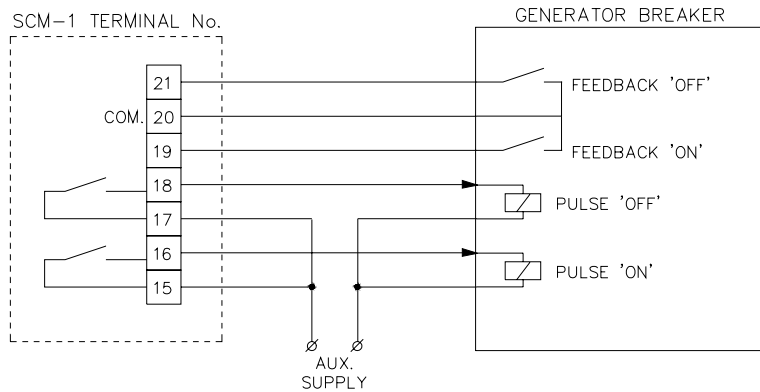

Principle wiring between the SCM-1 and the generator breaker control.

Only potential free contacts may be used for the GB position feedback input signals.

The GB ON/OFF commands are potential free relay outputs with the following contact ratings:

- Max.: AC: 250 V - 5 A - 1000VA
- DC: 250 V - 1 A - 50W

Wiring diagram for the synchronizing signals

The synchronizing unit consists of two parts:

- the control interface; *terminals 22 ... 28*
- the speed governor interface; *terminals 29 ... 40*

Selection of SWBD/PMS control for the DGU is made via the control interface. The SWBD control allows manually up/down control of the speed governor via push-buttons in the switchboard.

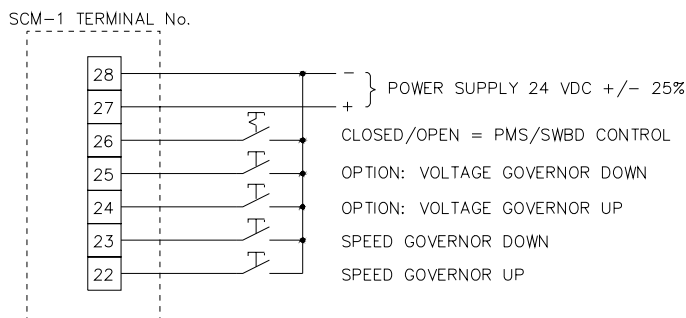

NOTE !

Supply voltage at the SCM-1 module power supply terminals is always required, both in SWBD and in PMS control. To secure the SWBD control the supply for the SCM-1 module should be fused separately.

The control interface incl. selection of SWBD/PMS control

SWBD control of the AVR is only available if the voltage control function (which is an additional function) is implemented in the DELOMATIC system.

Wiring diagrams for the speed governor outputs

The SCM-1 module has two different types of speed governor interfaces:

- analogue outputs for interface with electronic speed governors
- relay outputs for interface with mechanical speed governors

NOTE! *Only speed governors in speed droop mode may be used in co-operation with the DELOMATIC system.*

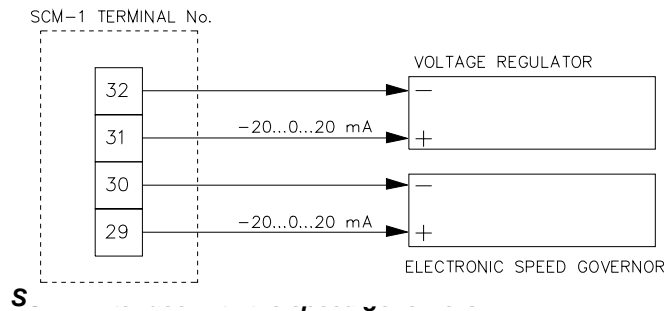

The terminals 29...32 are used for interfacing with an electronic speed governor and analogue output for the AVR.

The analogue output for AVR control is only available if the additional function for voltage control is implemented in the DELOMATIC system.

An analogue output (ESG) is available for interfacing with electronic speed governors if the SCM-1 module is not equipped with MSG relay outputs.

NOTE! *The analogue outputs range from -20...0...20 mA, max. 5 VDC. Voltage output may be achieved by connecting a shunt resistor; -5...0...5 VDC \leftrightarrow 250 Ω resistor.*

As optional functions the SCM-1 may be implemented with relay outputs for interface with mechanical speed governors (MSG) and mechanical controlled AVR's (MAVR). The implementation of the relay outputs for mechanical governors in the SCM-1 module, deactivates the corresponding analogue outputs.

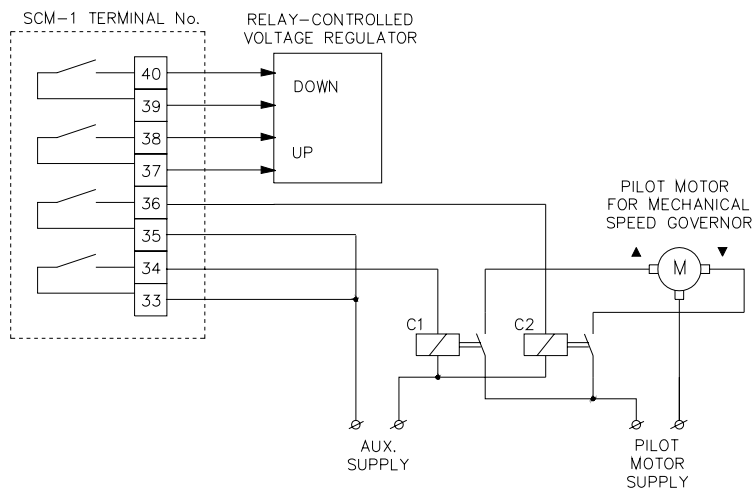

The terminals 33...40 are only available if the relay outputs for interface with mechanical governors are mounted into the SCM-1 module.

The illustration to the left shows how to connect the mechanical speed governors to the SCM-1 module.

Principle wiring of the mechanical speed governors.

NOTE! *If the Aux. supply is a DC supply, it is recommended to mount free-wheel diodes in parallel with the relay coils C1 and C2.*

If the pilot motor is of AC type, it is recommended to mount a noise reducing capacitor (0.1 μ F X-capacitor or similar) in parallel with the pilot motor terminals.

If the pilot motor is of DC type, it is recommended to mount a noise reducing capacitor (0.1 μ F, X-capacitor or similar) or a transzorb diode in parallel with the pilot motor terminals.

25.2.7 The SCM-2 module

The SCM-2 module consists of:

- the multi-transducer unit; *terminals 1 ... 14 located to the left at the SCM-2 front cover*
- the GB ON/OFF unit; *terminals 15 ... 21 located in the middle at SCM-2 front cover*

Wiring diagram for the multi transducer (AC measuring inputs)

The multi-transducer unit have three input groups:

- a three phase generator current measuring input
- a three phase generator voltage measuring input
- a three phase busbar voltage measuring input

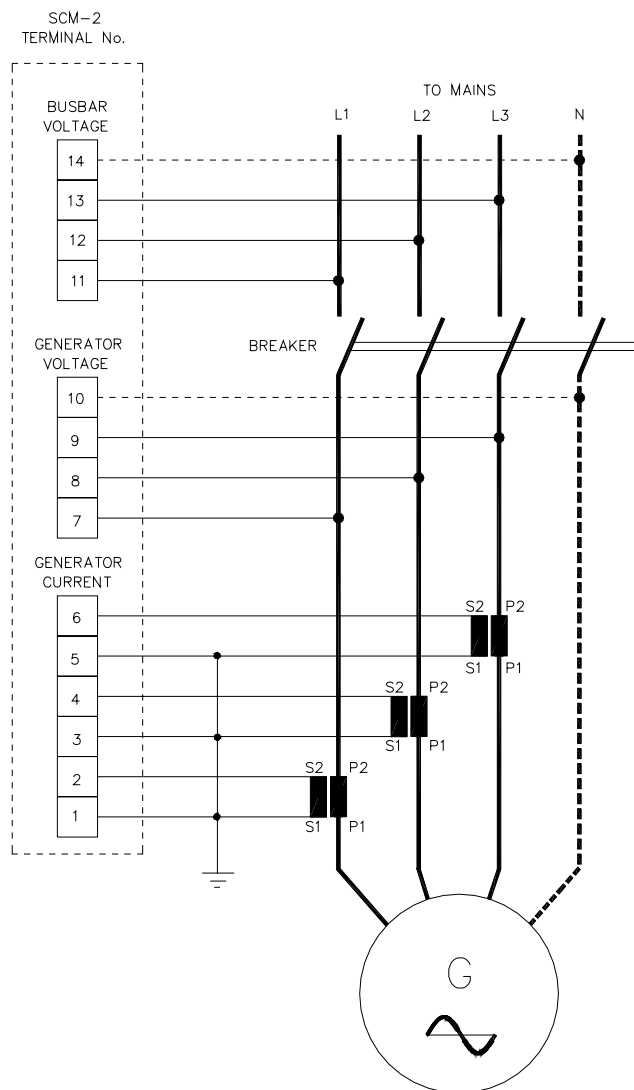

The voltage measuring inputs (both busbar and generator voltage inputs) are able to measure max. 660 VAC.

If measurement of higher voltages is required voltage transformers must be applied.

The shown wiring is the connection to a 3-wire grid with a neutral conductor (dotted lines).

If the SCM-2 is to measure at a 3-wire grid *without neutral conductor*, terminals 10 and 14 are left as open connections (*grounding of the unused "N" terminals must not be carried out*).

NOTE !

The screw terminals at the current measuring inputs must not be connected to more than max. 4 mm² single or multi-stranded wires/cords.

WARNING !

Short circuit the current measuring inputs before disconnecting the terminals (the SCM-2 module has internal current measuring transformers).

Principle wiring of the multi-transducer signals.

Wiring diagram generator breaker ON/OFF control signals

The generator breaker ON/OFF control signals consists of:

- two binary inputs for GB position feedback signals
- two relay outputs for GB ON/OFF commands

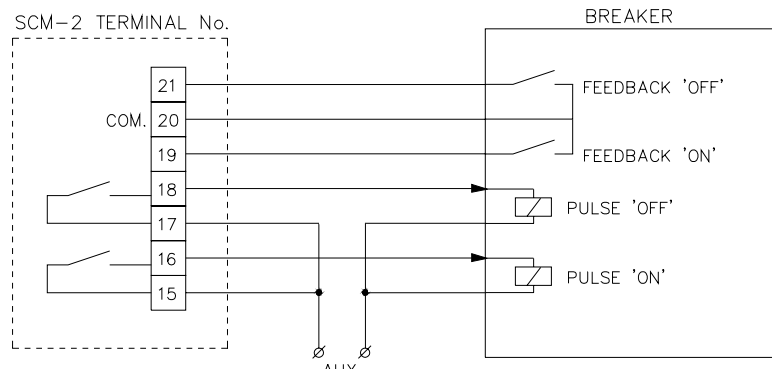

Principle wiring between the SCM-2 and the generator breaker.

Only potential free contacts may be used for the GB position feedback input signals.

The GB ON/OFF commands are potential free relay outputs with the following contact ratings:

Max.: AC: 250 V - 5 A - 1000VA
DC: 250 V - 1 A - 50W

NOTE! *It is recommended to mount free-wheel diodes in parallel if the breaker control operates by means of relay coils.*

25.2.8 The CRM-1 module for short circuit protection

Wiring diagram for the AC current measuring inputs

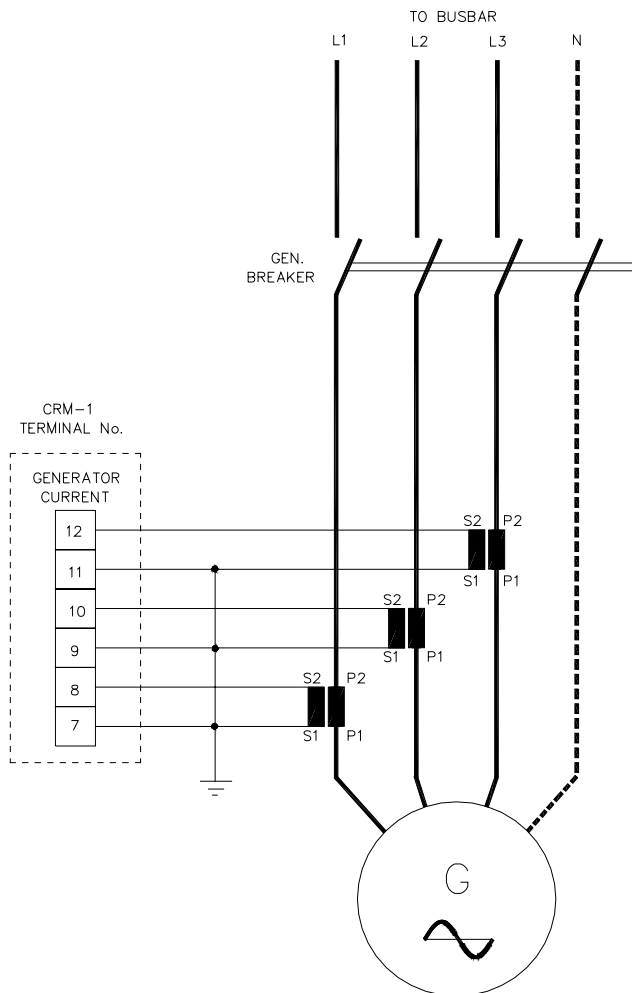

WARNING !

Short circuit the current measuring inputs before disconnecting the terminals (the CRM-1 module has internal current measuring transformers).

NOTE !

The screw terminals at the current measuring inputs must not be connected to more than max. 4 mm² single or multi-stranded wires/cords.

Principle wiring of the current measuring inputs.

Wiring the power supply and the control in- and outputs:

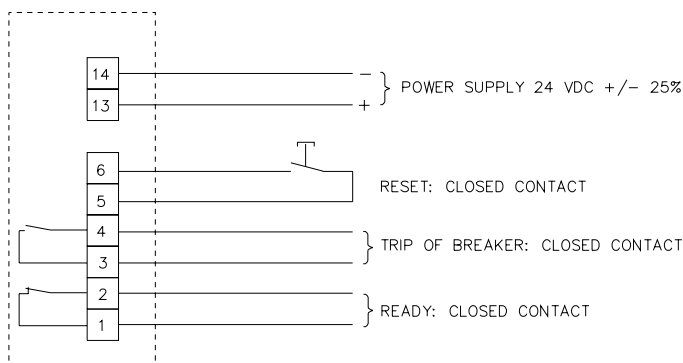

The power supply input must always be supplied on the CRM-1 module.

To secure the CRM-1 module functionality the power supply for the module should be fused separately.

NOTE !

It is recommended to mount free-wheel diodes in parallel if the breaker control operates by means of relay coils.

25.2.9 The CRM-1 module for differential current protection

IMPORTANT: *As the CRM-1 diff uses a non-compensated differential current measuring method, it is essential that the wires from the current transformers to the CRM-1 diff are of the same type and length.*

Wiring diagram for the AC current measuring inputs

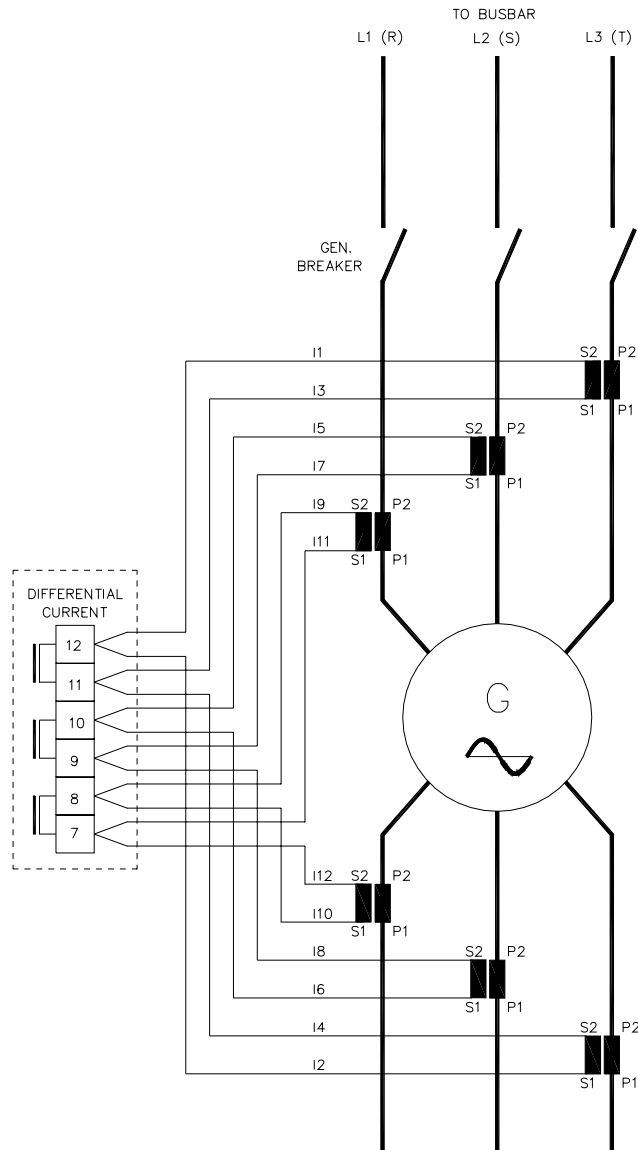

NOTE! The wire pairs must be of equal type and length: I1 = I2, I3 = I4 and so on.

WARNING !

Short circuit the current measuring inputs before disconnecting the terminals (the CRM-1 module has internal current measuring transformers).

NOTE !

The screw terminals at the current measuring inputs must not be connected to more than max. 4 mm² single or multi-stranded wires/cords.

Wiring the power supply and the control in- and outputs:

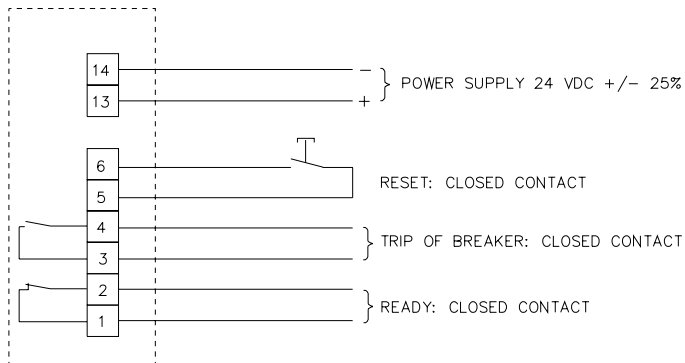

NOTE: To make the CRM-1 diff operational, the power supply on terminals 13 and 14 **must** be connected.

If the CRM-1 diff is to be used for fast de-excitation, the output on terminals 4 and 5 is to be used.

To secure the CRM-1 module functionality the power supply for the module should be fused separately.

NOTE ! *It is recommended to mount free-wheel diodes in parallel if the breaker control operates by means of relay coils.*