



-power in control



APPLICATION NOTES



DELOMATIC 4, DM-4 GAS

I/O assignment list



DEIF A/S · Frisenborgvej 33 · DK-7800 Skive
Tel.: +45 9614 9614 · Fax: +45 9614 9615
info@deif.com · www.deif.com

Document no.: 4189340654B
SW version 1.33.3 or later

Table of contents

1. ABOUT THIS DOCUMENT 3

 GENERAL PURPOSE 3

 INTENDED USERS..... 3

 CONTENTS/OVERALL STRUCTURE..... 3

2. WARNINGS AND LEGAL INFORMATION 4

 LEGAL INFORMATION AND RESPONSIBILITY..... 4

 ELECTROSTATIC DISCHARGE AWARENESS 4

 SAFETY ISSUES 4

 DEFINITIONS 4

3. GENERAL OVERVIEW 5

4. COMPONENTS..... 6

5. TERMINAL LAYOUTS..... 7

 TERMINAL LAYOUT IOM 4-2, MODULE #3, SPEED GOVERNOR 8

 TERMINAL LAYOUT IOM 4-2, MODULE #4, COOLING CIRCUITS..... 9

 TERMINAL LAYOUT IOM 4-2, MODULE #5, GAS MIXER 10

 TERMINAL LAYOUT IOM 4-2, MODULE #6 (OPTION)..... 11

1. About this document

General purpose

This document contains the application notes for DEIF's Delomatic 4, DM-4, used in gas applications.



For functional descriptions, the procedure for parameter setup, complete standard parameter lists, etc., please see the Installation Instructions.

The general purpose of the application notes is to offer the designer information about the I/O assignment list.



Please make sure to read this handbook before working with the DM-4 controller and the gen-set to be controlled. Failure to do this could result in damage to the equipment or human injury.

Intended users

The document is mainly intended for the person responsible for designing DM-4 systems. In most cases, this would be a panel builder designer. Naturally, other users might also find useful information in this document.

Contents/overall structure

The document is divided into chapters, and in order to make the structure of the document simple and easy to use, each chapter will begin from the top of a new page.

2. Warnings and legal information

Legal information and responsibility

DEIF takes no responsibility for installation or operation of the generator set. If there is any doubt about how to install or operate the generator set controlled by the unit, the company responsible for the installation or the operation of the set must be contacted.

The DM-4 is not to be opened by unauthorised personnel. If opened anyway, the warranty will be lost.

Electrostatic discharge awareness

Sufficient care must be taken to protect the terminals against static discharges during the installation. Once the unit is installed and connected, these precautions are no longer necessary.

Safety issues

Installing the unit implies work with dangerous currents and voltages. Therefore, the installation should only be carried out by authorised personnel who understand the risks involved in working with live electrical equipment.



Be aware of the hazardous live currents and voltages. Do not touch any AC measurement inputs as this could lead to injury or death.

Definitions

Throughout this document, a number of notes and warnings will be presented. To ensure that these are noticed, they will be highlighted in order to separate them from the general text.

Notes



The notes provide general information which will be helpful for the reader to bear in mind.

Warnings



The warnings indicate a potentially dangerous situation which could result in death, personal injury or damaged equipment, if certain guidelines are not followed.

3. General overview

The DM-4 Gas system consists as a minimum of a double-height (6 HE, 266 mm height) 19" rack mounted with the necessary I/O modules and a 12" colour graphic touchscreen operator interface.

The DM-4 Gas has a TCP/IP interface with a built-in webserver. This means that the graphic screens are stored here and can be accessed from any computer on the internet, using a free of charge DEIF HMI Client software and thereby enabling remote control and monitoring from anywhere in the world.

Connecting an RS232 GSM modem enables SMS clear text alarm messages.

General system layout:

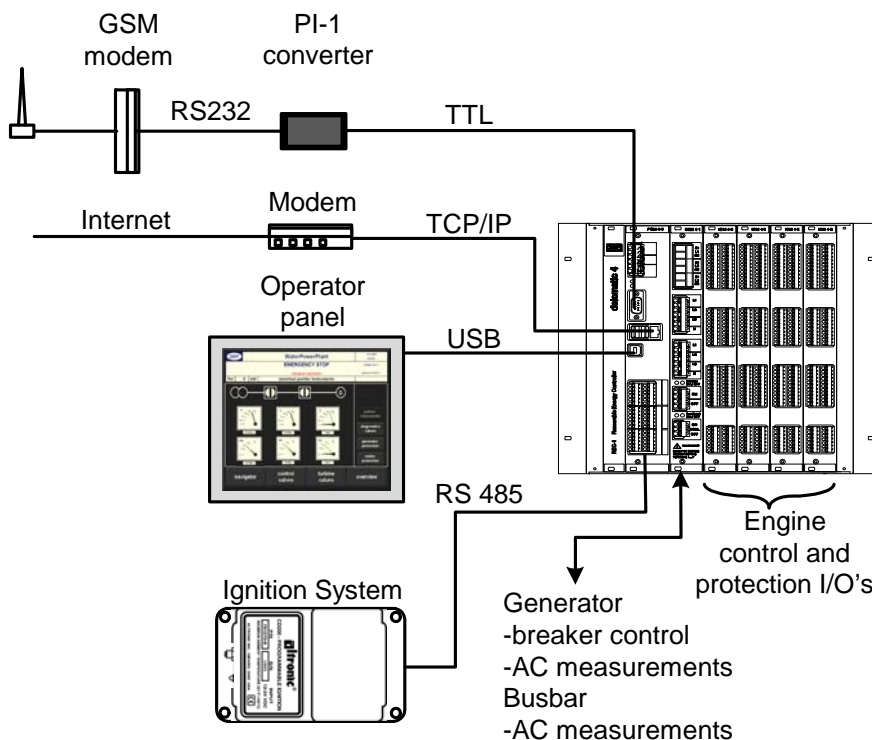

The ignition system and internet/GSM modems are not DEIF supply.

4. Components

For components used, please refer to the Installation Instructions.

5. Terminal layouts

Terminal layouts for PCM 4-3 and SCM 4-1 modules, please refer to the Installation Instructions.



The terminal layouts in the following are DEIF standard layouts. Adaptation to a specific project will be normal.

Terminal layout IOM 4-2, module #3, Speed governor

Temperature inputs

Type	Text	Term.	Term.	Text	Type
Pt100	Engine cooling water outlet	1	41	Heating water before exchanger	Pt100
		2	42		
		3	43		
		4	44		
Pt100	Lube oil temperature	5	45	Mixture cooling water inlet	Pt100
		6	46		
		7	47		
		8	48		
Pt100	Mixture temperature	9	49	Room air temperature	Pt100
		10	50		
		11	51		
		12	52		

Analogue 4-20 mA inputs

Text	Term.	Term.	Text
Throttle position	13	53	Lambda voltage
	14	54	
Not used	15	55	Not used
Lube oil pressure	16	56	Mixture pressure
	17	57	
Not used	18	58	Not used

Analogue 4-20 mA outputs

Text	Term.	Term.	Text
Throttle position regulator	19	59	Heating water circuit valve
	20	60	
Voltage/CosPhi regulator	21	61	Intercooler circuit valve
	22	62	

Digital inputs

Text	Term.	Term.	Text
Fire alarm	23	63	Measuring voltage missing
Emergency stop	24	64	GCB opened
Watchdog	25	65	GCB tripped
Safety chain closed	26	66	Water flow engine circuit
Low water level engine cooling circuit	27	67	Failure heating circuit
External mains failure	28	68	Gas alarm shutdown
Common for 23-28	29	69	Common for 63-68

Digital or RPM (pickup) inputs

Text	Term.	Term.	Text
Engine speed (NPN/PNP)	30	70	Configurable 2
	31	71	
Configurable 1	32	72	Configurable 3
	33	73	

Transistor (digital) outputs

Text	Term.	Term.	Text
Supply +	34	74	Supply +
Rearm safety chain	35	75	Open Gas valve A1
Open safety chain	36	76	Ignition ON
Close GCB	37	77	Starter ON (crank)
Trip GCB	38	78	Throttle position regulator ON
Open GCB	39	79	Gas compressor ON
Supply -	40	80	Supply -

Terminal layout IOM 4-2, module #4, Cooling circuits

Temperature inputs

Type	Text	Term.	Term.	Text	Type
Pt100	Engine water inlet	1	41	Heating water inlet temperature	Pt100
		2	42		
		3	43		
		4	44		
Pt100	Heating water after emergency cooler	5	45	Heating water after exchanger	Pt100
		6	46		
		7	47		
		8	48		
Pt100	Heating water return temperature	9	49	Cold junction	Pt100
		10	50		
		11	51		
		12	52		

Analogue 4-20 mA inputs

Text	Term.	Term.	Text
External load demand	13	53	Lube oil level
	14	54	
Not used	15	55	Not used
Cooling water pressure	16	56	Mains power
	17	57	
Not used	18	58	Not used

Analogue 4-20 mA outputs

Text	Term.	Term.	Text
kW	19	59	Frequency converter room temperature
	20	60	
Emergency cooling circuit valve	21	61	Room air flaps
	22	62	

Digital inputs

Text	Term.	Term.	Text
Start release	23	63	Gas pressure limiter A
Start demand	24	64	Gas tight control A succeeded
Acknowledge	25	65	Gas temperature limiter A
Filter maintenance	26	66	Exhaust gas back pressure limiter
CH4 calibrate	27	67	Room air temperature limiter
Auxiliary drives failure	28	68	Emergency cooling circuit failure
Common for 23-28	29	69	Common for 63-68

Digital or RPM (pickup) inputs

Text	Term.	Term.	Text
Configurable counter 1	30	70	Configurable counter 3
	31	71	
Configurable counter 2	32	72	Configurable counter 4
	33	73	

Transistor (digital) outputs

Text	Term.	Term.	Text
Supply +	34	74	Supply +
Cooling water pump ON	35	75	Emergency cooling pump and fan stage 1 ON
Heating water pump ON	36	76	Emer. cooling fan stage 2 ON
Cooling pump + fan stage 1 ON	37	77	Emer. cooling fan stage 3 ON
Cooling fan stage 2 ON	38	78	Waste oil pump ON
Cooling fan stage 3 ON	39	79	Fresh oil pump ON
Supply -	40	80	Supply -

Terminal layout IOM 4-2, module #5, gas mixer

Temperature inputs

Type	Text	Term.	Term.	Text	Type
NiCrNi	Exhaust temperature A	1	41	Spare	
		2	42		
		3	43		
		4	44		
NiCrNi	Exhaust temperature B	5	45	Exhaust temperature after exchanger	NiCrNi
		6	46		
		7	47		
		8	48		
NiCrNi	Exhaust temperature after CAT	9	49	Spare	
		10	50		
		11	51		
		12	52		

Analogue 4-20 mA inputs

Text	Term.	Term.	Text
CH4 value	13	53	Battery voltage
	14	54	
Not used	15	55	Not used
Level gas tank	16	56	Spare
	17	57	
Not used	18	58	Not used

Analogue 4-20 mA outputs

Text	Term.	Term.	Text
Gas mixer (internal)	19	59	Spare
	20	60	
Spare	21	61	Spare
	22	62	

Digital inputs

Text	Term.	Term.	Text
Gas mixer position lean	23	63	Spare
Low water level intercooler	24	64	Spare
Generator winding temperature limiter	25	65	Compressor gas pressure limiter
Lube oil level MAX	26	66	Gas alarm warning
Lube oil level MIN	27	67	Gas alarm device failure
Spare	28	68	Compressor gas temperature limiter
Common for 23-28	29	69	Common for 63-68

Digital or RPM (pickup) inputs

Text	Term.	Term.	Text
Spare	30	70	Spare
	31	71	
Spare	32	72	Spare
	33	73	

Transistor (digital) outputs

Text	Term.	Term.	Text
Supply +	34	74	Supply +
Gas mixer clock	35	75	Collective fault
Gas mixer direction	36	76	Collective warning
Engine cooling water preheating	37	77	Ready to start
Open room air flaps	38	78	Gas tight control A ON
Room air control release	39	79	kWh pulse output
Supply -	40	80	Supply -

Terminal layout IOM 4-2, module #6 (option)

Temperature inputs

Type	Text	Term.	Term.	Text	Type
Spare		1	41	Spare	
		2	42		
		3	43		
		4	44		
Spare		5	45	Spare	
		6	46		
		7	47		
		8	48		
Spare		9	49	Spare	
		10	50		
		11	51		
		12	52		

Analogue 4-20 mA inputs

Text	Term.	Term.	Text
Spare	13	53	Spare
	14	54	
Not used	15	55	Not used
Spare	16	56	Spare
	17	57	
Not used	18	58	Not used

Analogue 4-20 mA outputs

Text	Term.	Term.	Text
Spare	19	59	Spare
	20	60	
Spare	21	61	Spare
	22	62	

Digital inputs

Text	Term.	Term.	Text
Island operation	23	63	Lube oil day tank MAX
Gas type B	24	64	Exhaust bypass opened
Fresh oil storage tank MIN	25	65	Exhaust bypass closed
Spare	26	66	MCB opened
Waste oil MAX	27	67	MCB tripped
Lube oil day tank MIN	28	68	Gas pressure limiter B
Common for 23-28	29	69	Common for 63-68

Digital or RPM (pickup) inputs

Text	Term.	Term.	Text
Gas tight control B succeeded	30	70	Spare
	31	71	
Gas temperature limiter B	32	72	Spare
	33	73	

Transistor (digital) outputs

Text	Term.	Term.	Text
Supply +	34	74	Supply +
Close exhaust bypass	35	75	Open gas valve B
Close MCB	36	76	Throw off island stage 1
Trip MCB	37	77	Throw off island stage 2
Open MCB	38	78	Throw off island stage 3
Gas tight control B ON	39	79	Throw off island stage 4
Supply -	40	80	Supply -

DEIF A/S reserves the right to change any of the above.