



-power in control



INSTALLATION INSTRUCTIONS



Engine Control Unit, ECU 100

- Mounting
- Terminal overview
- Wiring
- Unit dimensions and cut-out



DEIF A/S · Frisenborgvej 33 · DK-7800 Skive
Tel.: +45 9614 9614 · Fax: +45 9614 9615
info@deif.com · www.deif.com

Document no.: 4189340802D
SW version:

1. General information

1.1. Warnings, legal information and safety.....	3
1.1.1. Warnings and notes	3
1.1.2. Legal information and disclaimer	3
1.1.3. Safety issues	3
1.1.4. Electrostatic discharge awareness	3
1.1.5. Factory settings	4
1.1.6. UL applications.....	4
1.2. About the installation instructions.....	4
1.2.1. General purpose	4
1.2.2. Intended users	4
1.2.3. Contents and overall structure	4

2. Mounting

2.1. ECU 100 mounting.....	5
2.1.1. Mounting of the unit.....	5
2.1.2. Unit dimensions and panel cutout.....	5
2.1.3. Tightening torques.....	6

3. Terminals

3.1. Terminal overview and description.....	7
3.1.1. Terminal overview	7
3.1.2. Terminal description.....	7

4. Wiring

4.1. Wiring diagram.....	11
4.2. DC connections.....	12
4.3. Digital inputs.....	13
4.4. Charger alternator connections.....	13

5. Communication

5.1. Wiring instructions.....	15
5.2. CANbus engine communication.....	16
5.2.1. Connection with 2-wire shielded cable (recommended).....	16
5.2.2. Connection with 3-wire shielded cable.....	17
5.3. Additional Operator Panel, AOP-2.....	18

1. General information

1.1 Warnings, legal information and safety

1.1.1 Warnings and notes

Throughout this document, a number of warnings and notes with helpful user information will be presented. To ensure that these are noticed, they will be highlighted as follows in order to separate them from the general text.

Warnings

 **Warnings indicate a potentially dangerous situation, which could result in death, personal injury or damaged equipment, if certain guidelines are not followed.**

Notes

 **Notes provide general information, which will be helpful for the reader to bear in mind.**

1.1.2 Legal information and disclaimer

DEIF takes no responsibility for installation or operation of the generator set. If there is any doubt about how to install or operate the engine/generator controlled by the Multi-line 2 unit, the company responsible for the installation or the operation of the set must be contacted.

 **The Multi-line 2 unit is not to be opened by unauthorised personnel. If opened anyway, the warranty will be lost.**

Disclaimer

DEIF A/S reserves the right to change any of the contents of this document without prior notice.

The English version of this document always contains the most recent and up-to-date information about the product. DEIF does not take responsibility for the accuracy of translations, and translations might not be updated at the same time as the English document. If there is a discrepancy, the English version prevails.

1.1.3 Safety issues

Installing and operating the Multi-line 2 unit may imply work with dangerous currents and voltages. Therefore, the installation should only be carried out by authorised personnel who understand the risks involved in working with live electrical equipment.

 **Be aware of the hazardous live currents and voltages. Do not touch any AC measurement inputs as this could lead to injury or death.**

1.1.4 Electrostatic discharge awareness

Sufficient care must be taken to protect the terminal against static discharges during the installation. Once the unit is installed and connected, these precautions are no longer necessary.

1.1.5 Factory settings

The Multi-line 2 unit is delivered from factory with certain factory settings. These are based on average values and are not necessarily the correct settings for matching the engine/generator set in question. Precautions must be taken to check the settings before running the engine/generator set.

1.1.6 UL applications

These flat surface panel-mounted controllers are intended to be used in Listed Generator Assemblies, where the suitability of the combination has been determined by Underwriters Laboratories.

1.2 About the installation instructions

1.2.1 General purpose

These Installation Instructions mainly include general product and hardware information, mounting instructions, terminal strip descriptions, I/O lists and wiring descriptions.

The general purpose of this document is to give the user important information to be used in the installation of the unit.



Please make sure to read this document before starting to work with the Multi-line 2 unit and the gen-set to be controlled. Failure to do this could result in human injury or damage to the equipment.

1.2.2 Intended users

These Installation Instructions are mainly intended for the person responsible for the design and installation. In most cases, this would be a panel builder designer. Naturally, other users might also find useful information in the document.

1.2.3 Contents and overall structure

This document is divided into chapters, and in order to make the structure simple and easy to use, each chapter will begin from the top of a new page.

2. Mounting

2.1 ECU 100 mounting

2.1.1 Mounting of the unit

Included in the package is 12 fixing clamps.

The unit is designed for flush mounting for both IP52 and IP65 mounting. For IP52, four fixing clamps are to be used; two at the top and two at the bottom.

For IP65, all 12 clamps must be mounted to comply with the rating.

2.1.2 Unit dimensions and panel cutout

The unit is designed for mounting in the panel front.

In order to ensure optimum mounting, the panel door must be cut out according to the following measurements:

$$H \times W = 151.00 \times 211.00 + 1.00 \text{ mm}$$

$$H \times W = 5.94" \times 8.31" + 0.04"$$

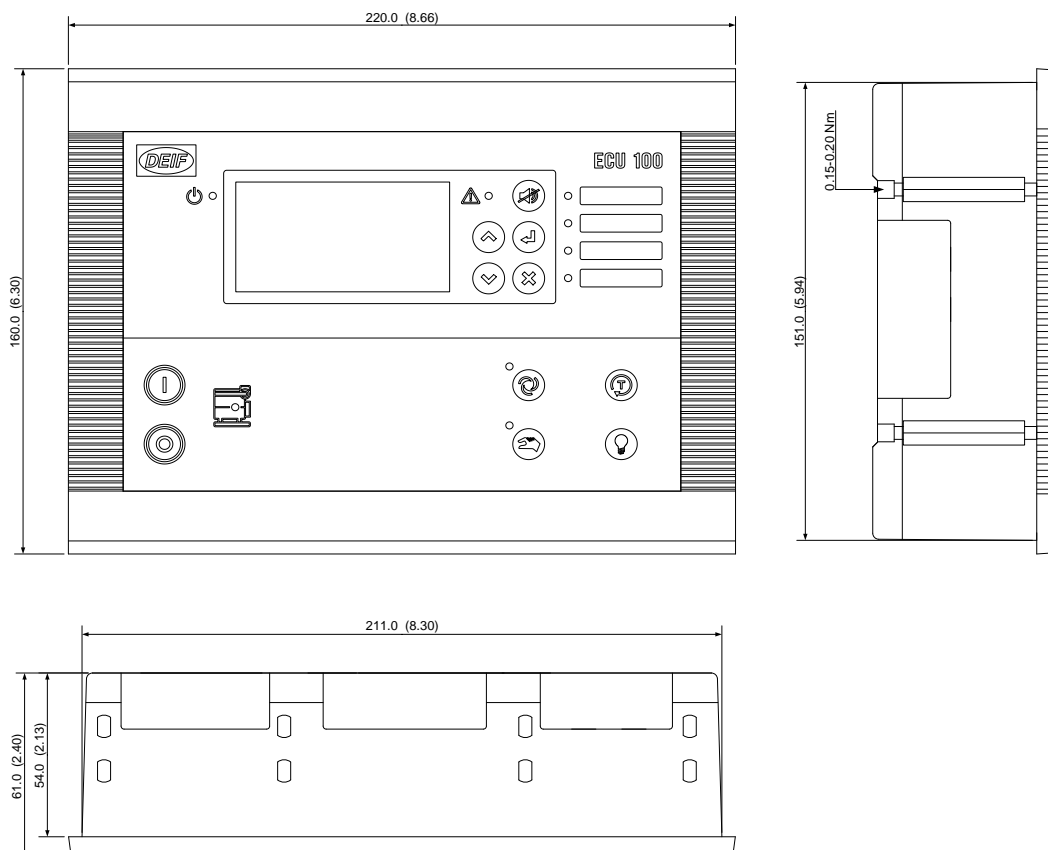

2.1.3 Tightening torques

- Unit panel door mounting: 0.15-0.20 Nm, 1.4-1.8 lb-in (see diagram in "Unit dimensions and panel cut-out")
- Plug connections (terminals): 0.5 Nm, 4.4 lb-in
- AOP-1 and AOP-2 (see diagram below)
- Panel door mounting: 0.7 Nm, 6.2 lb-in
- Sub-D screw: 0.2 Nm, 1.8 lb-in
- DC-DC converter terminals: 0.5 Nm, 4.4 lb-in

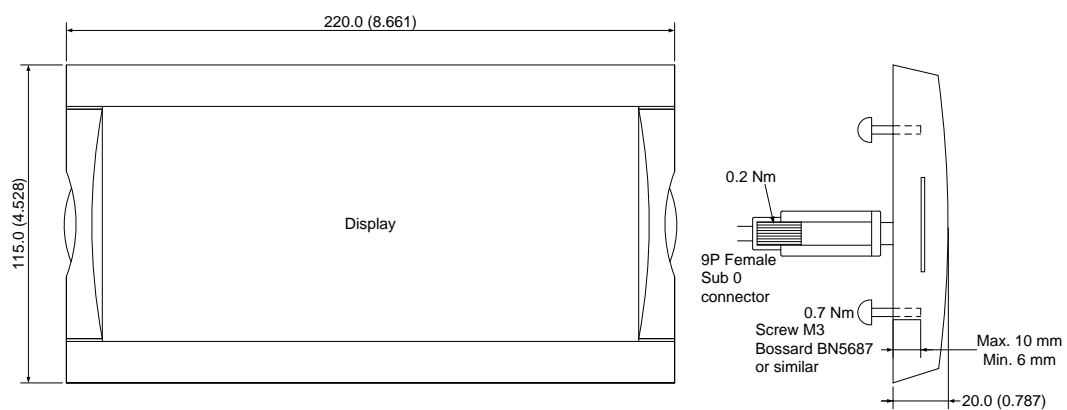

3. Terminals

3.1 Terminal overview and description

3.1.1 Terminal overview

Unit rear view

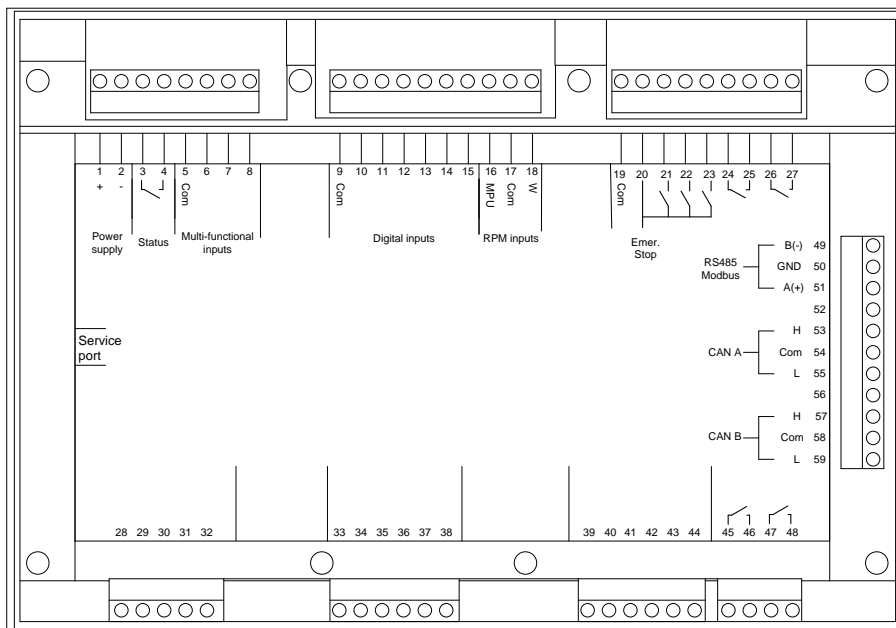

 The RJ11 connector for the PC connection interface box is placed on the side of the unit.

3.1.2 Terminal description

 For the relay outputs, the following terms will be used:
NO means Normally Open.
NC means Normally Closed.
Com. means common terminal for the individual relay.

Terminal	Technical data	Description
1	Power supply +	6...36V DC (UL/cUL Listed: 7.5...32.7V DC)
2	Power supply –	0V DC
3-4	Status out/configurable. Contact ratings 1 A 24V DC/V AC Resistive	See note*
9	Common	Common for term. 10...15
10	Digital input	Start enable/configurable
11	Digital input	Remote start/stop/configurable
12	Digital input	Charge alternator D+ (running)/configurable
13	Digital input	Configurable
14	Digital input	Coolant temperature/configurable
15	Digital input	Oil pressure/configurable
19	Common	Common for emergency stop term. 20
20	Emergency stop and common for 21...23	Common for relay 21, 22 and 23 and input for emergency stop**
21	Relay output 21. Contact ratings 2 A 30V DC/ V AC (UL/cUL Listed: 1 A Resistive)	Start prepare/configurable. Function NO
22	Relay output 22. Contact ratings 2 A 30V DC/ V AC (UL/cUL Listed: 1 A Resistive)	Starter (crank)/configurable. Function NO
23	Relay output 23. Contact ratings 2 A 30V DC/ V AC (UL/cUL Listed: 1 A Resistive)	Run coil/configurable. Function NO
24-25	Relay output 24. Contact ratings 8 A 30V DC/ V AC (UL/cUL Listed: 6 A Resistive)	Horn/configurable. Function NO
26-27	Relay output 26. Contact ratings 8 A 30V DC/ V AC (UL/cUL Listed: 6 A Resistive)	Alarm/configurable. Function NO
45	Relay R45. Contact ratings 2 A 30V DC/250V AC. (UL/cUL Listed: Contact ratings 2 A 30V DC/ 30V AC).	Configurable, function NO
46	Relay R45	
47	Relay R47. Contact ratings 2 A 30V DC/250V AC. (UL/cUL Listed: Contact ratings 2 A 30V DC/ 30V AC).	Configurable, function NO
48	Relay R47	
Multi-functional inputs		
5	Common	Common for term. 6...8
6	RMI 1/4...20 mA/digital input	Fuel level/configurable
7	RMI 2/4...20 mA/digital input	Oil pressure/configurable
8	RMI 3/4...20 mA/digital input	Water temp./configurable
Tacho RPM input		

Terminal	Technical data	Description
16	RPM input (MPU)	Magnetic pick-up
17	RPM-GND	Common for RPM input
18	RPM input (W/L)	Magnetic pick-up. PNP, NPN or charge alternator W terminal
Modbus RS485 interface		
49	B (-)	Modbus RS485 RTU or ASCII
50	Data GND	
51	A (+)	
CANbus port A: Engine interface		
53	CAN-H	CAN J1939 engine communication
54	Data GND	
55	CAN-L	
Optional CANbus port B: AOP-2 interface		
57	CAN-H	CAN communication line to AOP-2
58	Data GND	
59	CAN-L	

* The status relay is the uP watchdog output. This relay is normally energised, and the switch is closed after power-up. If the uP fails or the power is lost, the relay will de-energise and the switch will open. If the unit fails to start up at power-up, then the relay switch will remain open.

** If terminal 20 is used for emergency stop, please see wiring diagram below.

The relay output functions are configurable via the PC utility software and can be configured to cover the following functions:

- Alarm/limit
- Engine run indication
- Horn
- Idle speed output
- Not used
- Prepare
- Run coil
- Starter
- Stop coil
- Engine heater
- Fuel pump

It is possible to choose run coil on one relay and stop coil on another, thus supporting engines with double systems.

The multi-functional inputs can be configured to cover the following functions:

- RMI sensor input
- 4...20 mA input
- Digital input with wire break (switch function)

Tacho RPM input (MPU) can be configured to cover the following functions:

- Magnetic pick-up (2-wire)
- NPN or PNP pick-up*

* These RPM inputs require external equipment.

Tacho RPM input with capacitor (W/L) can be configured to cover the following functions:

- Magnetic pick-up (2-wire)
- W terminal on charger alternator
- NPN or PNP pick-up*

* These RPM inputs require external components.

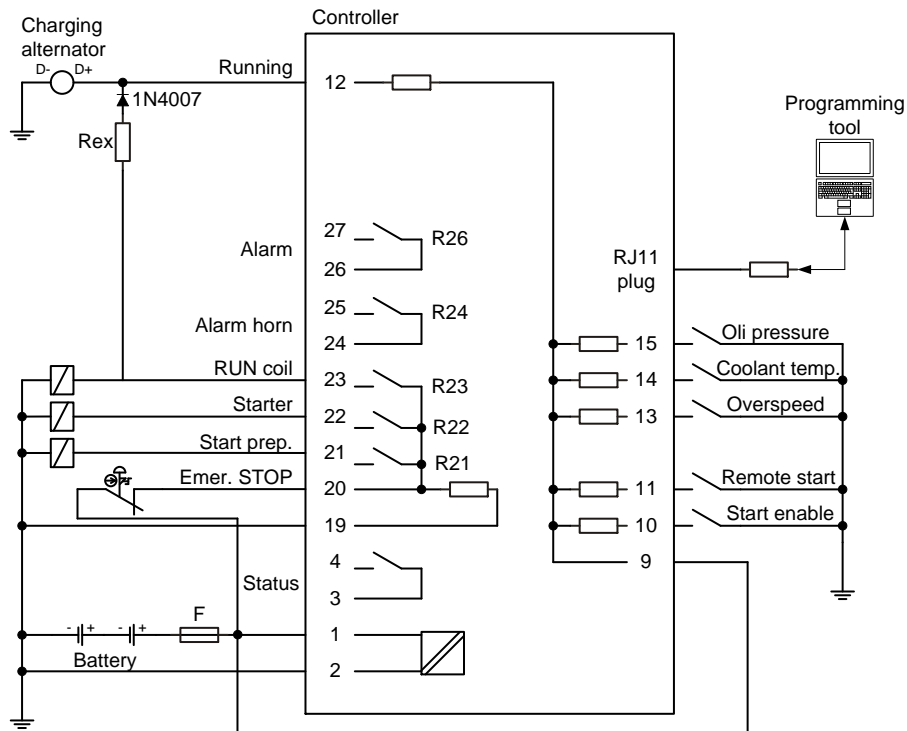

4. Wiring

4.1 Wiring diagram



Term. 12 can be used as alarm input if not used for charger generator terminal D+

Rex: 12 V systems: 47 Ω 4 W
24 V systems: 100 Ω 6 W

-  If a stop coil is used, the REX resistor can be connected to the starter relay (crank).
-  The illustrated configuration is an example of settings. The use of the relays can be chosen freely.
-  It is important to protect the unit against damage caused by high voltages. Therefore, the fuse must not be more than 2 A slow-blow.

4.2 DC connections

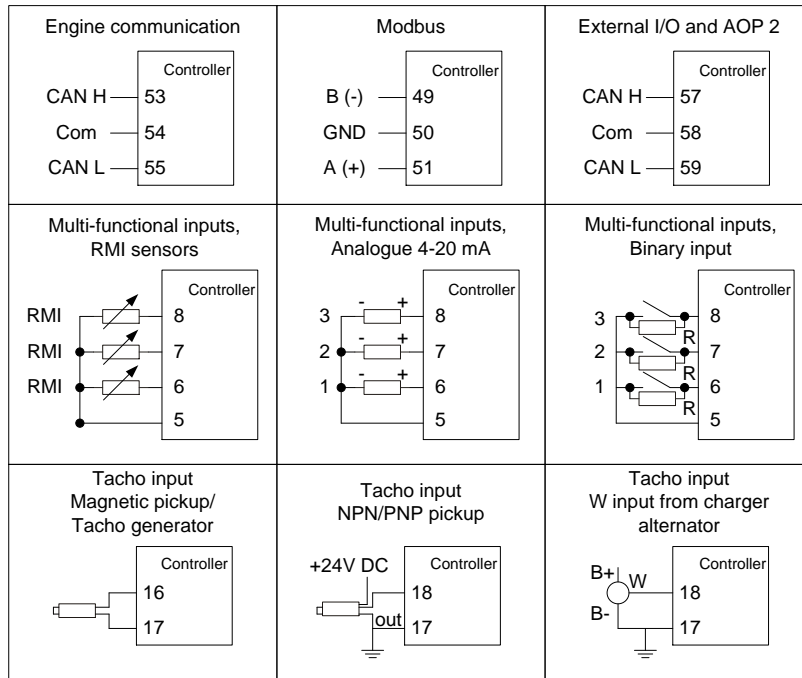

Connection example 4-20 mA

Active transducer

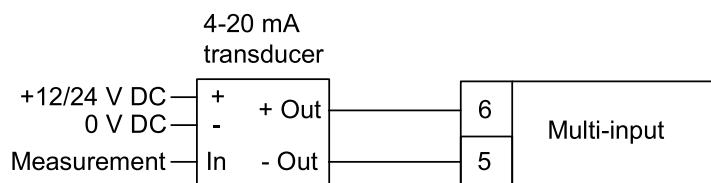

Passive transducer

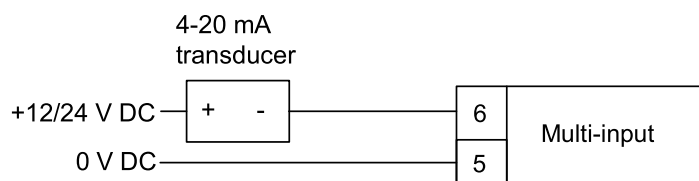

4.3 Digital inputs

All digital inputs are 12/24V DC bi-directional optocoupler type. The typical wiring is illustrated below:

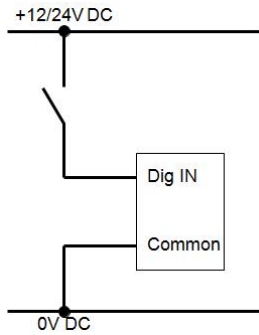

4.4 Charger alternator connections

The charger alternator can be used as running-feedback in two different ways:

1. Using the D+ terminal connected to terminal 12
2. Using the W terminal connected to the RPM input



Usually only one of these possibilities is used.

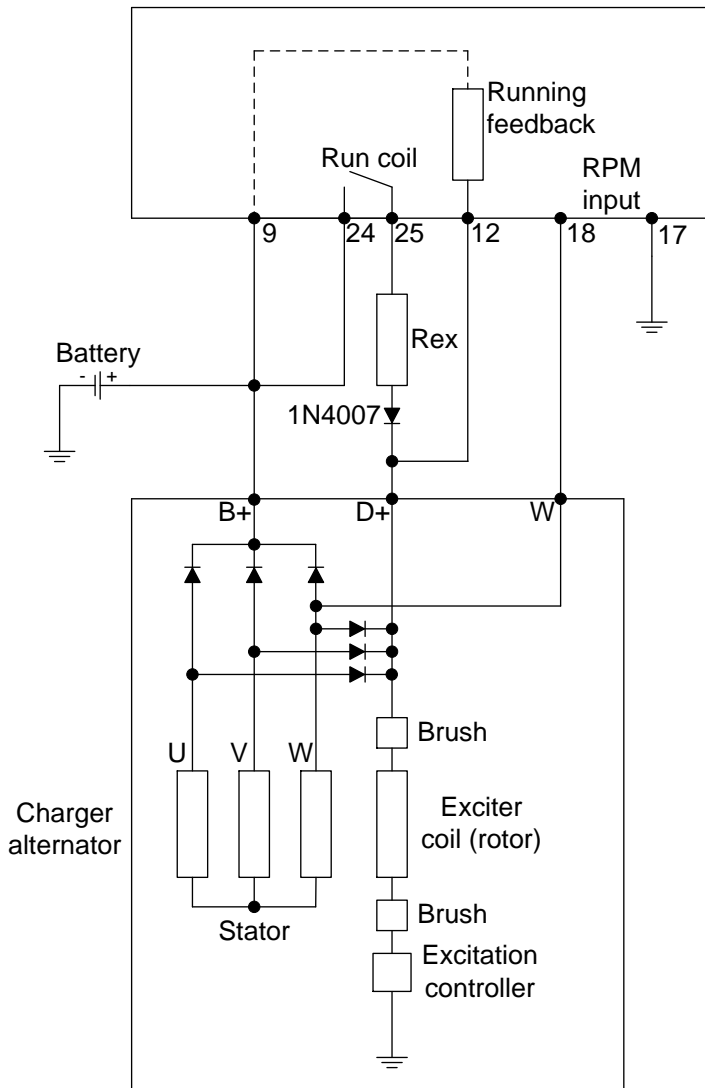

Rex: Excitation resistor	12 V systems: 47 Ω 4 W
	24 V systems: 100 Ω 6 W

At standstill, the battery + is connected to terminal 9 (common), and a current flows to terminal 12 and via the D+ input on the alternator to ground (battery -). When the starter is engaged (cranking), the battery will supply the D+ through the REX resistor, helping the alternator to excite. When the alternator starts to produce voltage (excitation OK), the speed of the alternator will be above running speed, and the voltage on term. 12 will rise to a value higher than the battery voltage and then interrupt the current flow through REX and activate the running feedback input. Engine is running.



If a stop coil is used, the REX resistor can be connected to the starter relay (crank).

5. Communication

5.1 Wiring instructions

Cable

Belden 3106 A or equivalent. 22 AWG (0.324 mm²) shielded twisted pair, min. 95 % shield coverage.

Cable shield

Connect the cable shield to earth at one end only.

GND terminal connection

In case of communication problems, the GND terminals of the unit and the external device can be linked together using a third wire.

CAN bus termination resistor

The size of the terminating resistors should be 120 Ω 1 %, 0.5 W resistor.



Never connect the GND terminal to earth directly or through the shield!



If the GND terminal is connected to a PLC or other device, the GND connection of this device must be isolated from earth!



Maximum length of the CAN bus line is 400 m.

5.2 CANbus engine communication

5.2.1 Connection with 2-wire shielded cable (recommended)

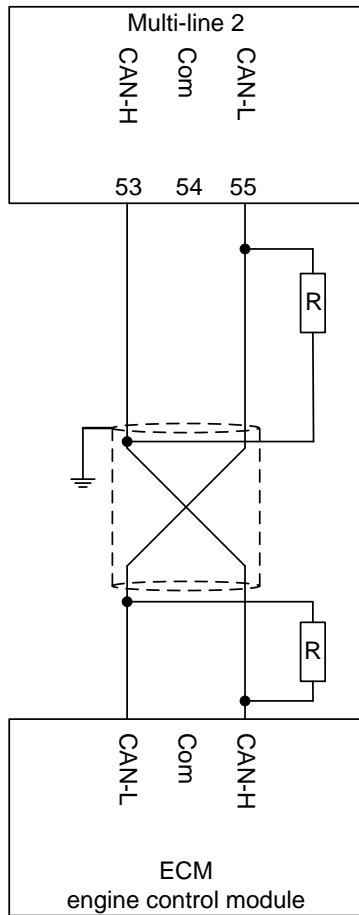

5.2.2 Connection with 3-wire shielded cable

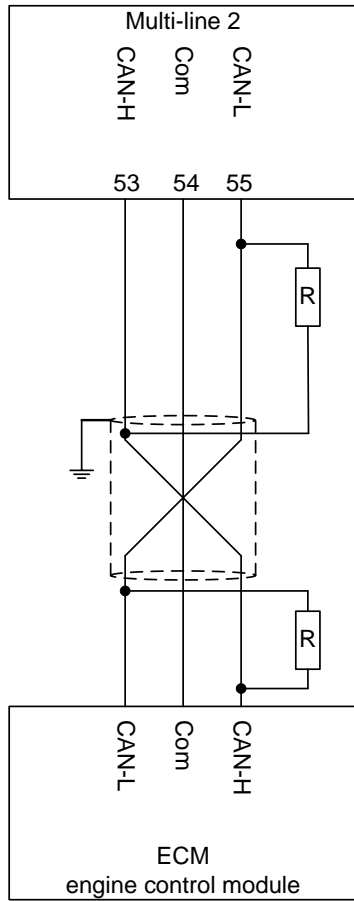

5.3 Additional Operator Panel, AOP-2

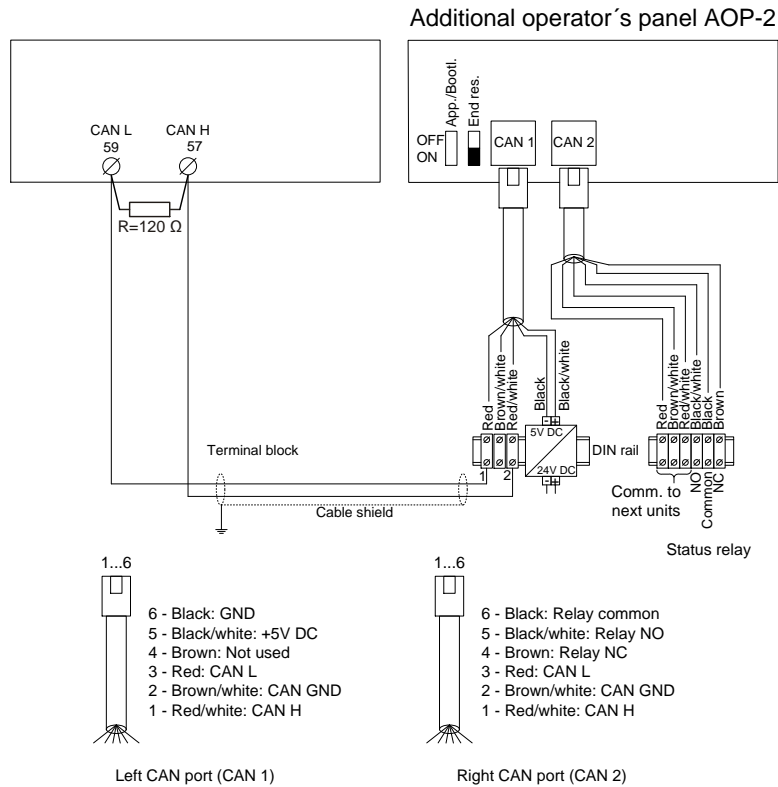

i For wiring details, please refer to “Wiring instructions” in this section.

i A DC/DC converter for the DC supply voltage and 2x1 m cable with an RJ12 plug in one end and stripped wires in the other end are included in the AOP-2 delivery.