



-power in control



## DATA SHEET



### **Panorama Rudder Indicator, TRI-2**

- Class 1 accuracy on CAN version
- Readable from up to 5 metres
- Single and dual CAN or analogue interface
- LED illumination



DEIF A/S · Frisenborgvej 33 · DK-7800 Skive  
Tel.: +45 9614 9614 · Fax: +45 9614 9615  
info@deif.com · www.deif.com

Document no.: 4921250066D  
SW version: N/A

## 1. General information

1.1. Technology and application.....	3
1.1.1. Technology.....	3
1.1.2. Application.....	3
1.2. Scale colour, illumination and dimming.....	4
1.2.1. Scale colour.....	4
1.2.2. Illumination.....	4
1.2.3. Dimmer.....	4
1.2.4. CAN dimming.....	4
1.3. Mounting, cabling and labelling.....	4
1.3.1. Mounting.....	4
1.3.2. Cable entry.....	4

## 2. Technical information

2.1. Terminals and technical specifications.....	5
2.1.1. Terminals, CAN version.....	5
2.1.2. Terminals, analogue version.....	6
2.1.3. Technical specifications.....	7

## 3. Ordering information

3.1. Order specifications and disclaimer.....	9
3.1.1. Order specifications.....	9
3.1.2. Order steps of TRI-2 CAN.....	9
3.1.3. Disclaimer .....	10

# 1. General information

## 1.1 Technology and application

### 1.1.1 Technology

DEIF's TRI-2 panorama rudder angle indicator is based on a well-known moving coil system which secures a fast response.

In the CAN version, a micro controller ensures class 1 accuracy and even opens up for an expanded scale centre to achieve better readout accuracy around rudder zero. The below example illustrates a scale with an expanded mid section.

40...30...20...10...5...0...5...10...20...30...40

### Versions and dimensions

Two basic versions are available:

- TRI-2 Analogue (standard voltage and current inputs, 3-wire rudder interface)
- TRI-2 CAN (single and dual CAN)

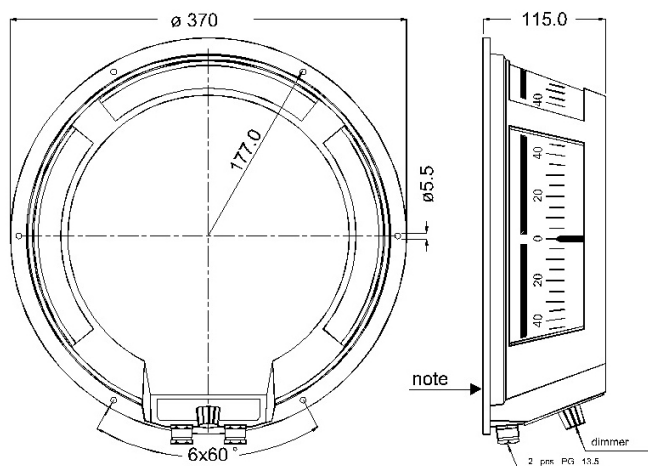

The type label is located at the base of the indicator. Therefore it is recommended to note the order number before mounting the indicator. If service is needed later on, the order number will be required to identify the instrument.

### 1.1.2 Application

The panorama rudder angle indicator type TRI-2 is applied for the indication of the rudder position on the bridge.

The TRI-2 is CE-marked for marine, residential, commercial and light industry plus industrial environment. It is housed in a matt black, splash-proof case for deck-head suspension.

Equipped with three large scales, the TRI-2 ensures quick and easy reading of the rudder position from any angle up to 250° and from a distance of up to 5 metres.

## 1.2 Scale colour, illumination and dimming

### 1.2.1 Scale colour

The indicator is available with two scale types:

1. White scales with black figures, division lines and black pointer.
2. Black scales where the figures, division lines and the pointer are yellow.

On both white and black scales, starboard is marked with a green section (to the right), port with a red section (to the left) underneath the division lines. Reversed scales and scales with centre expansion are available on request.

### 1.2.2 Illumination

The TRI-2 is equipped with long-life LEDs, ensuring easy and clear reading of the scales in the dim light on the bridge.

The standard colour is yellow. On the CAN version it can be set up to red or advanced dimmer function where the light changes to red colour at low settings for better night vision. Notice that if red illumination is used, the green colour looks black.

White scales are translucent, implying that the division lines and the figures are clearly visible, and that the pointer is seen clearly as a shadow.

On black scales, the figures, the division lines and a broad, yellow section underneath these are translucent and illuminated. The pointer is clearly visible as a shadow against this yellow section.

### 1.2.3 Dimmer

The light intensity can be changed by means of a built-in dimmer, accessible on the rear plate of the indicator. If remote dimming is preferred, the built-in dimmer potentiometer may be removed from the indicator (after dismantling of the rear plate) and mounted e.g. in a control panel. The maximum cable length is 100 m. A plug for sealing of the hole in the rear plate is included in the delivery.

### 1.2.4 CAN dimming

Dimming may also be controlled from the CANbus, in this case the built-in analogue dimmer is inhibited (custom-specific CAN option).

## 1.3 Mounting, cabling and labelling

### 1.3.1 Mounting

The TRI-2 is intended for mounting on the deck head by means of six 5 mm screws. It is important that the deck is level so the instrument is not deformed when the screws are fastened.



**Note that if extra holes are drilled, the warranty will no longer be valid.**

### 1.3.2 Cable entry

Cable entry via PG 13.5 cable glands.

## 2. Technical information

### 2.1 Terminals and technical specifications

#### 2.1.1 Terminals, CAN version

Pin no.	Function	CANopen	Note
1	Supply voltage	+12 V-24V DC	Consumption 12 V 300 mA/24 V 150 mA
2	"	0V DC	"
3	CAN connection	CAN 2 H input	CAN 2 line
4	"	CAN 2 L input	"
5	"	CAN 2 GND	"
6	"	NC	"
7	"	CAN 1 H input	CAN 1 line
8	"	CAN 1 L input	"
9	"	CAN 1 GND	"
10	Illumination	Dimmer wiper	Dimmer control via 1k ohm 2 W potentiometer
11	"	Dimmer ref.	"

#### Label

	CAN OPEN	NMEA 2000
1	Supply: 12V-24V	
2	Supply: 0V	
3	CAN2-H	Net-H White
4	CAN2-L	Net-L Blue
5	CAN2-GND	Net-C Black
6	NC	Net-S Red
7	CAN1-H	NC
8	CAN1-L	
9	CAN1-GND	
10	Dimmer Wiper	
11	Dimmer Reference	

The connection terminals are located under the rear plate. A fumble wheel (integrated push-button/rotating switch) is located between the two sets of connectors. The wheel is used for the entire setup together with the two LEDs marked 1 and 2 located on each side of the switch.

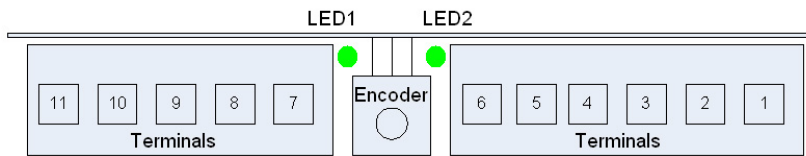

The following can be set using the fumble wheel:

1. Zero adjustment (centre point on the scale). Max. adjustment (end point on the scale).
2. Reverse the pointer direction CW or CCW. Selection of CAN ID.
3. Dimmer select group 1.....8 and the CAN protocol to be used. Backlight colour, yellow, red or auto shift.

For further details regarding the set-up, see the installation manual on [www.deif.com](http://www.deif.com).

### 2.1.2 Terminals, analogue version

The connection terminals are located under the rear plate.

For general current/voltage:

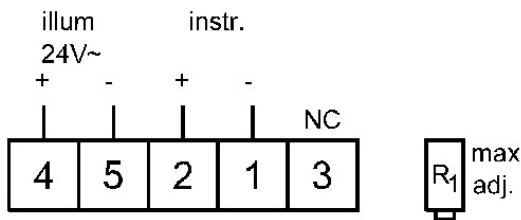

For 3-wire rudder interface:

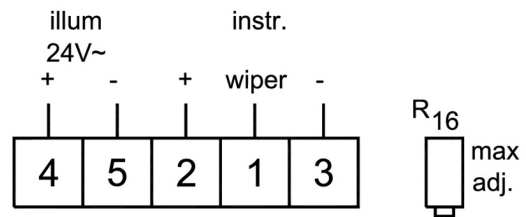

#### Measuring ranges (DC input only):

Voltage		
Lowest:	Highest:	Load:
0...4 V	0...100 V	0.7 kΩ/V
-2...0...2 V	-100...0...100 V	1.4 kΩ/V
Current		
Lowest:	Highest:	Load:
0...1 mA	0...100 mA	3.0 V
-1...0...1 mA	-100...0...100 mA	1.5 V
4...12...20 mA		4.0 V

## 2.1.3 Technical specifications

TRI-2 has been designed according to the below standards		Standards/remarks
Power supply	12 V or 24V DC (9.0 to 31.2V DC)	Only CAN version
	24V AC/DC -25/+30% for illumination	Analogue version
Power consumption	≤ 4 W with full illumination	
Interface	Single CAN and dual CAN	CAN version
	Standard analogue interface or 3-wire rudder interface	Analogue version, see measuring range table
Galvanic separation	600 V, 50 Hz, 1 minute between: Power supply, CAN 1, CAN 2	
Safety	Cat. III, poll. dg. 2, 550V AC rms, 50 Hz, 1 minute	EN 61010-1
Accuracy (CAN)	Class 1 in the range -10...15...30...55°C	IEC/EN 60051
Accuracy (analogue)	Class 1.5 in the range -10...15...30...55°C	IEC/EN 60051
Pointer	Increasing positive input moves pointer CW	CW: Left to right
Extended accuracy	Improved accuracy around zero can be achieved by expanding the centre of the scale (partial linear scale) The feature is optional	Only CAN version
Temperature	-10 to +55°C nominal, -25 to +70°C operating, -25 to +70°C storage	EN 60051
Start-up time	< 5 sec. from power on to valid pointer position	Only CAN version
Cable dimension	0.2 to 2.5 mm <sup>2</sup>	
Cable entries	Two PG13.5 cable outer diameter 6 to 12 mm	
Mounting	6 x ø5.5 mm holes	
Compass safety distance	1 metre (40 inch)	IEC/EN 60945
Protection	IP54	IEC/EN 60529
Relative humidity	0 to 95% without condensation	IEC/EN 60068-1/2
Pressure	600 to 1100 hPa	
Vibration	3 to 13.2 Hz: 2 mm (peak-peak) 13.2 to 100 Hz: 0.7 g	EN IEC 60945, EN/IEC60068-2-6 and DNV Class A
EMC	CE-marked for marine, light industrial and industrial environment	IEC 60945, EN 61000-6-1/2/3/4 60255-22-1
Housing	Plastic housing: Polycarbonate +10% glass fibre Metal parts: Made out of corrosion-resistant materials	UL94 V0
Weight	2080 g	

<b>TRI-2 has been designed according to the below standards</b>		<b>Standards/remarks</b>
Dimensions, card-board box	380 x 380 x 145 mm	
Approvals	Type-approved according to:	MED Directive



## 3. Ordering information

### 3.1 Order specifications and disclaimer

#### 3.1.1 Order specifications

Mandatory information						
Item no.	Type (housing)	Variant no.	Protection	Input type	Input range <sup>1)</sup>	Scale design <sup>2)</sup>

Mandatory information						
Item no.	Type (housing)	Variant no.	Protection	Input type	Input range <sup>1)</sup>	Scale design <sup>2)</sup>
2951460020	TRI-2	01	IP54	Analogue, single	0...1 V	4155110751
2951460020	TRI-2	02	IP54	CANopen	All versions included	4155110751

#### Notes:

- 1) Input range must be selected within the range stated in the table in paragraph 2.1.2. Input range 0...1 V is used as an example.
- 2) Scale design must be selected from DEIF's range of standard designs (document no. 4921290030), or a new custom design must be made. Design 4155110751 is used as an example.

#### 3.1.2 Order steps of TRI-2 CAN

To order a TRI-2 CAN, the following parameters must be defined:

- Source ID
- CAN transmitter bit resolution
- CAN zero angle
- Pointer direction
- Backlight
- Dimmer group

#### Select source node ID

The source ID is used to define from which transmitter the TRI-2 will listen for data. The source node ID (sID) value can be set from 1 to 127, default value is 1.

The TRI-2 receives pointer data from TPDO 0x180 + "Source Node ID" + Offset.

The offset can only be set at the menu in the TRI-2 during installation and can be set from 0 to 7. Offset default value is 0.

#### Example:

CAN encoder RTC 300 or RTC 600 with default settings from DEIF.

The CAN encoder transmits data on 0x181 as a 16 byte value with data in byte 0 and 1.

The TRI-2 now receives data from the CAN encoder. Adjustment in the TRI-2 menu makes it possible to set the TRI-2 to receive data from another TPDO than 0x181 if needed. The range in this example will be from 0x181 to 0x188 (0x181+0x7).

Order the TRI-2 with source node ID 1 to receive CAN data from TPDO 0x181, from for instance DEIF RTC 300 or DEIF RTC 600.

#### **Select resolution of encoder**

Define the resolution of the CAN encoder values to select from: 12-bit, 13-bit, 14-bit, 15-bit or 16-bit.

#### **CAN zero angle**

It is possible to define which CAN value should be used as 0. It is possible to select between Zero and Half range.

1. Zero: when the CAN value 0 is transmitted to the TRI-2, the pointer will be positioned at 0 deg. Use this if a DEIF RTC encoder is used in the application.
2. Half range: if a 12-bit encoder is used, the value of 2047 (0x7FF, half range) is required to position the TRI-2 pointer at zero. For a 16-bit encoder, the half range value is 32767 (0x7FFF) which will position the pointer at zero.

#### **Pointer direction**

Define direction CW or CCW. Default is CW.

#### **Scale number**

Select from predefined scales, see the document "Illuminated indicators, standard scale designs 4921290030 UK" on [www.deif.com](http://www.deif.com) for further info.

#### **Backlight**

Select the desired colour of the LED to be used for backlight: "Auto", "Red" or "Yellow" (Yellow is default).

### **3.1.3 Disclaimer**

DEIF A/S reserves the right to change any of the contents of this document without prior notice.

The English version of this document always contains the most recent and up-to-date information about the product. DEIF does not take responsibility for the accuracy of translations, and translations might not be updated at the same time as the English document. If there is a discrepancy, the English version prevails.